

OPTIMAL INTEGRATED ATTITUDE AND STATE ESTIMATION FOR LUNAR DESCENT TO LANDING NAVIGATION

Renato Zanetti* and Robert H. Bishop†

Conditions on the optimality of the introduction of preprocessed attitude estimates in the Kalman filter are developed. The results are applied to lunar descent to landing navigation. The attitude estimate is obtained with the Davenport q-method and a modified measurement model. Together with the attitude estimate, the preprocessor passes to the Kalman filter the estimation error covariance.

INTRODUCTION

The optimal approach to estimate the spacecraft state (position, velocity, and attitude) is an integrated single estimator, such as the Kalman filter,^{1,2} or its nonlinear (non-optimal) extension, the extended Kalman filter (EKF).³ Modern sensor technologies often provide “smart” measurements, that are estimates derived from the raw data. Examples of such sensors are GPS receivers, quaternion star cameras, and terrain cameras that provide relative position. The advantage of these sensors is that they relieve the central filter from some of the computational load. However they can introduce correlations that need to be accounted for to produce a correct implementation. This work will focus on the introduction of an attitude estimate into the Kalman filter, but equivalent conclusions can be drawn for position estimates obtained by GPS or a terrain camera.

An integrated attitude and translation (position and velocity) estimator requires that we consider the nature of the group of rotations in three dimensions, $SO(3)$. Being that $SO(3)$ is not a vector space adds complexity to the process of estimating attitude in a Kalman filter. The fact that no three-dimensional representation of attitude can be globally continuous and non-singular⁴ makes it desirable to introduce a higher dimensional representation that results in a constrained state. If the attitude is represented through the quaternion-of-rotation⁵ the constraint is given by the unitary norm of the quaternion. However, the Kalman filter algorithm does not naturally permit the introduction of constraints. So, during the update stage of the estimate process, the attitude quaternion estimate can violate the unitary norm constraint. To avoid poor performance, the constraint should be included in the filter.^{6,7} Modifications to the EKF to estimate the quaternion include the additive EKF,⁸ the multiplicative EKF,⁹ and the rotational EKF.¹⁰ These three approaches retain the basic structure of the EKF, relying on linearization to estimate the quaternion.

Other classes of attitude estimation algorithms operate directly on the nonlinear structure of the problem. The Davenport q-method¹¹ is a nonlinear least-squares solution and was shown to be a maximum likelihood solution under specific assumptions on the distribution of the measurements.¹² Other nonlinear approaches exist, such as TRIAD,¹³ that determines the rotation matrix directly.

*Senior Member of the Technical Staff, GN&C Manned Space Systems. The Charles Stark Draper Laboratory, INC. rzanetti@draper.com

†Professor and Chairman, Department of Aerospace Engineering and Engineering Mechanics. The University of Texas at Austin. rhbishop@mail.utexas.edu

Also, nonlinear observers have been investigated.^{14,15} These nonlinear attitude determination algorithms are not easily augmented to include position and velocity states (one such example is Extended QUEST¹⁶).

The designer is therefore left to choose between estimating the attitude through a linearized approach using a single filter that optimally accounts for the correlation between attitude and other states, or to employ a nonlinear attitude determination algorithm that will decentralized the estimation effort, and by doing so possibly lose optimality.

The Kalman filter is the recursive solution to the linear weighted least squares problem.¹⁷ The Kalman estimate is the minimum variance estimate when the errors are zero mean and the least squares weights are chosen as the inverse of the error covariances.¹⁷ These additional assumptions (zero mean white noises and knowledge of the covariances) are not overly restrictive and allow for easy determination of the weight matrices, which correspond to the Kalman filter tuning parameters. Making further additional assumptions (the conditional distribution is symmetric and unimodal) the Kalman filter solution can also be interpreted as the maximum likelihood estimate.¹⁸ Gaussian distributions of the noises satisfy these additional assumptions. The optimality of the Kalman filter (in a minimum variance sense) is distribution independent, and generally there is no reason to assume a particular distribution. In this work all derivations are from an “engineering” approach without assuming knowledge of the distribution but only knowledge of the first two moments.

Ref. 19 draws the conclusion that the estimate obtained with the q-method is a sufficient statistics²⁰ of the vector observations, therefore it can be used as a preprocessor of the Kalman filter. The derivation assumes that both the Davenport q-method and the Kalman filter are maximum likelihood estimators. This assumption requires specific distributions of the measurement errors and the absence of non-attitude states in the vector observations used by the q-method. In this work that conclusion will be extended not to require any particular distribution. The case when the vector measurements used by the Davenport q-method are a function of non-attitude states will also be considered. Our approach extends the result by removing those assumptions. Assuming a distribution is an additional requirement that normally the navigation engineer does not make.

The contributions of this work are:

1. Optimal fusion of attitude estimates of the Davenport q-method with a standard (translational) navigation algorithm for Lunar descent to landing navigation.
2. A modified estimation error covariance and measurement model for the Davenport q-method are derived.
3. Treatment of measurement vectors that depend on states other than the attitude itself.

DAVENPORT Q-METHOD

The Wahba problem²¹ consists in determining the orthogonal matrix \mathbf{T} that minimizes the performance index

$$\mathcal{J}(\bar{\mathbf{q}}) = \frac{1}{2} \sum_{i=1}^n w_i \|\hat{\mathbf{y}}_i - \mathbf{T} \hat{\mathbf{n}}_i\|^2, \quad (1)$$

where $\hat{\mathbf{y}}_i$ are vector observations and $\hat{\mathbf{n}}_i$ are their representation in the reference frame. This minimization problem can be reformulated for the quaternion $\bar{\mathbf{q}}$, substituting the rotation matrix \mathbf{T} with

$$\mathbf{T}(\bar{\mathbf{q}}) = \mathbf{I} - 2q[\mathbf{q}\times] + 2[\mathbf{q}\times]^2,$$

where q and \mathbf{q} are the scalar and vector components, respectively. The orthogonality requirement is replaced with a unitary norm constrain on $\bar{\mathbf{q}}$. An elegant solution to this problem is due to Davenport and is given by Keat.¹¹ The minimization of Wahba performance index in Eq. (1) is equivalent to maximization of

$$\mathcal{J}^*(\bar{\mathbf{q}}) = \bar{\mathbf{q}}^T \mathbf{K} \bar{\mathbf{q}},$$

where matrix \mathbf{K} is given by

$$\mathbf{K} = \begin{bmatrix} \mathbf{S} - \sigma \mathbf{I}_{3 \times 3} & \mathbf{z} \\ \mathbf{z}^T & \sigma \end{bmatrix}, \quad (2)$$

and

$$\begin{aligned} \mathbf{B} &\triangleq \sum_{i=1}^n w_i \hat{\mathbf{y}}_i \hat{\mathbf{n}}_i^T & \sigma &\triangleq \text{trace}(\mathbf{B}) \\ \mathbf{S} &\triangleq \mathbf{B} + \mathbf{B}^T & \mathbf{z} &\triangleq \sum_{i=1}^n w_i (\hat{\mathbf{y}}_i \times \hat{\mathbf{n}}_i). \end{aligned}$$

Adjoining the constraint $\|\bar{\mathbf{q}}\|_2 = 1$ to the performance index with a Lagrange multiplier, denoted by λ , the first-order optimal condition is given by the eigenvalue problem

$$\mathbf{K} \bar{\mathbf{q}} = \lambda \bar{\mathbf{q}}. \quad (3)$$

The performance index can be shown to be

$$\mathcal{J}^* = \lambda.$$

Since the performance index is to be maximized, the optimal Lagrange multiplier is given by the maximum eigenvalue of \mathbf{K} defined in Eq. (2), and the optimal quaternion is given by the corresponding unit eigenvector. There is no need to calculate the eigenvector. The vector of Rodrigues parameters is given by

$$\boldsymbol{\rho} = \mathbf{q}/q.$$

The first three rows of Eq. (3) can be expanded to be

$$(\mathbf{S} - \sigma \mathbf{I}_{3 \times 3}) \mathbf{q} + \mathbf{z} q = \lambda \mathbf{q},$$

from which the estimated Gibbs vector is found to be

$$\hat{\boldsymbol{\rho}} = [(\sigma + \lambda) \mathbf{I}_{3 \times 3} - \mathbf{S}]^{-1} \mathbf{z}. \quad (4)$$

The optimal quaternion is given by

$$\hat{q} = \frac{1}{\sqrt{1 + \hat{\boldsymbol{\rho}}^T \hat{\boldsymbol{\rho}}}} \begin{bmatrix} \hat{\boldsymbol{\rho}} \\ 1 \end{bmatrix}. \quad (5)$$

Ref. 22 shows how to handle Eq. (4) when matrix $(\sigma + \lambda) \mathbf{I}_{3 \times 3} - \mathbf{S}$ is singular. The same paper shows a numerically efficient algorithm to compute the eigenvalue referred to as QUEST. Covariance analysis is also performed in Ref. 22 under the assumption of a simplified measurement model, known as the QUEST measurement model. The i^{th} measurement is modeled as

$$\hat{\mathbf{y}}_i = \mathbf{T}(\bar{\mathbf{q}}) \mathbf{n}_i + \tilde{\mathbf{y}}_i = \mathbf{T}(\bar{\mathbf{q}}) (\hat{\mathbf{n}}_i - \tilde{\mathbf{n}}_i) + \tilde{\mathbf{y}}_i,$$

where \mathbf{n}_i are the true reference vectors while $\tilde{\mathbf{n}}_i$ and $\tilde{\mathbf{y}}_i$ are errors. Vectors \mathbf{y}_i and \mathbf{n}_i are assumed to be unitary, and the measurement error covariances are given by

$$E \{ \tilde{\mathbf{n}}_i \tilde{\mathbf{n}}_i^T \} = \sigma_{n,i}^2 (\mathbf{I}_{3 \times 3} - \mathbf{n}_i \mathbf{n}_i^T),$$

and

$$E \{ \tilde{\mathbf{y}}_i \tilde{\mathbf{y}}_i^T \} = \sigma_{y,i}^2 (\mathbf{I}_{3 \times 3} - \mathbf{y}_i \mathbf{y}_i^T),$$

where \mathbf{y}_i are the true values of the measurements $\mathbf{y}_i = \mathbf{T}(\bar{\mathbf{q}}) \mathbf{n}_i$. Since \mathbf{n}_i and \mathbf{y}_i are unknown, they have to be replaced by $\hat{\mathbf{n}}_i$ and $\hat{\mathbf{y}}_i$ when calculating the two covariances.

Covariance Analysis

The matrix associated with the true observations is defined as

$$\mathbf{B}_{true} \triangleq \sum_{i=1}^n w_i \mathbf{y}_i \mathbf{n}_i^T,$$

and the matrix associated with the measurement error

$$\delta \mathbf{B} \triangleq \sum_{i=1}^n w_i \tilde{\mathbf{y}}_i \mathbf{n}_i^T + \sum_{i=1}^n w_i \mathbf{y}_i \tilde{\mathbf{n}}_i^T.$$

Therefore to first-order in the errors

$$\mathbf{B} = \mathbf{B}_{true} + \delta \mathbf{B}.$$

Similar quantities can be defined for \mathbf{z} , σ , and \mathbf{S}

$$\mathbf{z} = \mathbf{z}_{true} + \delta \mathbf{z}, \quad \mathbf{S} = \mathbf{S}_{true} + \delta \mathbf{S}, \quad \sigma = \sigma_{true} + \delta \sigma,$$

obtaining

$$\begin{aligned} \mathbf{z}_{true} &= \sum_{i=1}^n w_i (\mathbf{y}_i \times \mathbf{n}_i) & \delta \mathbf{z} &= \sum_{i=1}^n w_i (\mathbf{y}_i \times \tilde{\mathbf{n}}_i + \tilde{\mathbf{y}}_i \times \mathbf{n}_i) \\ \mathbf{S}_{true} &= \mathbf{B}_{true} + \mathbf{B}_{true}^T & \delta \mathbf{S} &= \delta \mathbf{B} + \delta \mathbf{B}^T \\ \sigma_{true} &= \text{trace } \mathbf{B}_{true} & \delta \sigma &= \text{trace } \delta \mathbf{B}. \end{aligned}$$

Provided that at least two independent vector measurements are available, the estimate obtained from \mathbf{B}_{true} using Davenport's algorithm is the true quaternion. Define

$$\mathbf{M} \triangleq (\sigma + \lambda) \mathbf{I}_{3 \times 3} - \mathbf{S},$$

the true Gibbs vector is

$$\boldsymbol{\rho} = \mathbf{M}_{true}^{-1} \mathbf{z}_{true},$$

where

$$\mathbf{M}_{true} = (\sigma_{true} + \lambda_{true}) \mathbf{I}_{3 \times 3} - \sum_{i=1}^n w_i \mathbf{y}_i \mathbf{n}_i^T - \sum_{i=1}^n w_i \mathbf{n}_i \mathbf{y}_i^T. \quad (6)$$

The estimated Gibbs vector is

$$\begin{aligned}\hat{\boldsymbol{\rho}} &= (\mathbf{M}_{true} + \delta\mathbf{M})^{-1} (\mathbf{z}_{true} + \delta\mathbf{z}) \simeq (\mathbf{M}_{true}^{-1} - \mathbf{M}_{true}^{-1} \delta\mathbf{M} \mathbf{M}_{true}^{-1}) (\mathbf{z}_{true} + \delta\mathbf{z}) \\ &\simeq \boldsymbol{\rho} + \mathbf{M}_{true}^{-1} \delta\mathbf{z} - \mathbf{M}_{true}^{-1} \delta\mathbf{M} \boldsymbol{\rho} = \boldsymbol{\rho} - \tilde{\boldsymbol{\rho}},\end{aligned}$$

where a first-order approximation was used. Defining a rotational estimation error such that $\mathbf{T}(\bar{\mathbf{q}}) = \mathbf{T}(\delta\bar{\mathbf{q}})\mathbf{T}(\hat{\bar{\mathbf{q}}})$, and using the composition rule for the Rodrigues parameters

$$\delta\mathbf{q} \simeq \delta\boldsymbol{\rho} = \frac{\mathbf{I}_{3 \times 3} - [\boldsymbol{\rho} \times]}{1 + \boldsymbol{\rho}^T \boldsymbol{\rho} - \boldsymbol{\rho}^T \tilde{\boldsymbol{\rho}}} \tilde{\boldsymbol{\rho}}, \quad (7)$$

using Mac-Laurin series

$$(1 + \boldsymbol{\rho}^T \boldsymbol{\rho} - \boldsymbol{\rho}^T \tilde{\boldsymbol{\rho}})^{-1} \simeq (1 + \boldsymbol{\rho}^T \boldsymbol{\rho})^{-1} + (1 + \boldsymbol{\rho}^T \boldsymbol{\rho})^{-2} \boldsymbol{\rho}^T \tilde{\boldsymbol{\rho}},$$

substituting in Eq. (7), the following first order approximation results

$$\delta\mathbf{q} \simeq \frac{\mathbf{I}_{3 \times 3} - [\boldsymbol{\rho} \times]}{1 + \boldsymbol{\rho}^T \boldsymbol{\rho}} \tilde{\boldsymbol{\rho}} = q (q\mathbf{I}_{3 \times 3} - [\mathbf{q} \times]) \tilde{\boldsymbol{\rho}},$$

finally

$$\delta\mathbf{q} = (q\mathbf{I}_{3 \times 3} - [\mathbf{q} \times]) \mathbf{M}_{true}^{-1} (\delta\mathbf{M} \mathbf{q} - q\delta\mathbf{z}). \quad (8)$$

In Ref. 22 the authors notice that the covariance should be approximately independent from the true state, therefore Eq. (8) is evaluated at a convenient true state, the identity quaternion, resulting in

$$\delta\mathbf{q} = -\mathbf{M}_{true}^{-1} \delta\mathbf{z}.$$

Assuming the covariance is independent from the true attitude, i.e. is independent from the body frame, the body frame can be rotated to coincide with the reference frame for covariance calculation purposes. If that was the case reference vectors \mathbf{n}_i would stay the same, but new measurements $\hat{\mathbf{y}}_i^*$ would occur

$$\hat{\mathbf{y}}_i^* = \mathbf{T}(\bar{\mathbf{q}})^T \hat{\mathbf{y}}_i = \mathbf{n}_i + \mathbf{T}(\bar{\mathbf{q}})^T \tilde{\mathbf{y}}_i.$$

Hence

$$\mathbf{T}(\bar{\mathbf{q}})^T \mathbf{y}_i \rightarrow \mathbf{y}_i, \quad \mathbf{T}(\bar{\mathbf{q}})^T \tilde{\mathbf{y}}_i \rightarrow \tilde{\mathbf{y}}_i$$

it follows that

$$\delta\boldsymbol{\theta} \simeq 2\delta\mathbf{q} = -2\mathbf{M}_{true}^{-1} \sum_{i=1}^n w_i (\mathbf{T}(\bar{\mathbf{q}})^T \mathbf{y}_i \times \tilde{\mathbf{n}}_i + \mathbf{T}(\bar{\mathbf{q}})^T \tilde{\mathbf{y}}_i \times \mathbf{n}_i), \quad (9)$$

and the following covariance formulation is obtained

$$\mathbf{P}_{\boldsymbol{\theta}\boldsymbol{\theta}}^i = 4(\mathbf{M}_{true}^i)^{-1} \sum_{i=1}^n w_i^2 \left\{ [\mathbf{n}_i \times] (\mathbf{R}_{n,i} + \mathbf{T}(\bar{\mathbf{q}})^T \mathbf{R}_{y,i} \mathbf{T}(\bar{\mathbf{q}})) [\mathbf{n}_i \times]^T \right\} (\mathbf{M}_{true}^i)^{-T},$$

where the symmetric matrix \mathbf{M}_{true}^i is given by

$$\mathbf{M}_{true}^i = -2 \sum_{i=1}^n w_i [\mathbf{n}_i \times]^2.$$

The errors $\tilde{\mathbf{n}}_i$ and $\tilde{\mathbf{y}}_i$ are assumed to be uncorrelated from each other, and

$$\mathbb{E} \{ \tilde{\mathbf{y}}_i \tilde{\mathbf{y}}_j^T \} = \mathbf{R}_{y,i} \delta_{ij}, \quad \mathbb{E} \{ \tilde{\mathbf{n}}_i \tilde{\mathbf{n}}_j^T \} = \mathbf{R}_{n,i} \delta_{ij}, \quad i, j = 1..n.$$

The matrix $\mathbf{P}_{\theta\theta}^i$ is the error covariance expressed in the inertial frame. Rotating it into the body frame, we obtain

$$\mathbf{P}_{\theta\theta}^b = 4(\mathbf{M}_{true}^b)^{-1} \sum_{i=1}^n w_i^2 \left\{ [\mathbf{y}_i \times] (\mathbf{T}(\bar{\mathbf{q}}) \mathbf{R}_{n,i} \mathbf{T}(\bar{\mathbf{q}})^T + \mathbf{R}_{y,i}) [\mathbf{y}_i \times]^T \right\} (\mathbf{M}_{true}^b)^{-T}, \quad (10)$$

where \mathbf{M}_{true}^b is given by

$$\mathbf{M}_{true}^b = -2 \sum_{i=1}^n w_i [\mathbf{y}_i \times]^2. \quad (11)$$

If the measurements covariances follow the QUEST measurement model, and if the weights are chosen such that

$$w_i = \frac{1}{\sigma_n^2 + \sigma_y^2},$$

then the QUEST error covariance formulation is obtained

$$\mathbf{P}_{\theta\theta}^{QUEST} = \left(\sum_{i=1}^n w_i [\mathbf{y}_i \times]^2 \right)^{-1} = \left\{ \text{trace} [\mathbf{T}(\bar{\mathbf{q}}) \mathbf{B}_{true}^T] \mathbf{I}_{3 \times 3} - \mathbf{T}(\bar{\mathbf{q}}) \mathbf{B}_{true}^T \right\}^{-1}. \quad (12)$$

Since $\mathbf{T}(\bar{\mathbf{q}})$ and \mathbf{B}_{true} are unknown they need to be substituted by $\mathbf{T}(\hat{\mathbf{q}})$ and \mathbf{B} .

Often times the reference vectors $\hat{\mathbf{n}}_i$ are functions of the spacecraft position, for example in the case of a Earth horizon sensor. In those cases the position estimate needs to be provided by another system, and is useful to derive the cross covariance.

$$\hat{\mathbf{n}}_i = \hat{\mathbf{n}}_i(\hat{\mathbf{r}}) \simeq \mathbf{n}_i + \tilde{\mathbf{n}}_i + \mathbf{A}_i \mathbf{e}_r, \quad \mathbf{e}_r \triangleq \mathbf{r} - \hat{\mathbf{r}}, \quad \mathbf{A}_i \triangleq \left. \frac{d\hat{\mathbf{n}}_i}{d\mathbf{r}} \right|_{\mathbf{r}=\hat{\mathbf{r}}}$$

therefore it follows immediately that

$$\mathbf{P}_{\theta r} = 2(\mathbf{M}_{true}^b)^{-1} \sum_{i=1}^n w_i [\mathbf{y}_i \times] \mathbf{A}_i \mathbf{P}_{rr}, \quad (13)$$

assuming $\tilde{\mathbf{n}}_i$, $\tilde{\mathbf{y}}_i$, and \mathbf{e}_r are all uncorrelated to each other, $\mathbf{P}_{rr} = \mathbb{E} \{ \mathbf{e}_r \mathbf{e}_r^T \}$ is provided externally, and the attitude error is in the body frame.

MEASUREMENT MODEL

The QUEST measurement model assumes that the measurement error lays on a plane tangent to the unit sphere on which the vector measurements lay. It also requires that the two components of the error have the same variance and are uncorrelated. Both these assumptions were relaxed in Ref. 23, where a model valid for large field-of-view sensors was developed. The unit vector measurements are given by:

$$\mathbf{y}_i = \frac{1}{\sqrt{1 + a_i^2 + b_i^2}} \begin{bmatrix} -a_i \\ -b_i \\ 1 \end{bmatrix}$$

assuming the focal length is one. The partial derivative of \mathbf{y}_i with respect to $\mathbf{a}_i \triangleq [a_i \ b_i]^T$ is

$$\mathbf{J}_i = \frac{1}{\sqrt{1 + a_i^2 + b_i^2}} \begin{bmatrix} -1 & 0 \\ 0 & -1 \\ 0 & 0 \end{bmatrix} - \frac{1}{1 + a_i^2 + b_i^2} \mathbf{y}_i \mathbf{a}_i^T.$$

Hence, the measurement covariance is given by

$$\mathbf{R}_i = \mathbf{J}_i \mathbf{R}_i^{\text{FOCAL}} \mathbf{J}_i^T$$

where $\mathbf{R}_i^{\text{FOCAL}}$ is the error covariance associated with \mathbf{a}_i .

Often the camera measurement can be more conveniently modeled based on the measurement of two angles α and β along two perpendicular directions¹² rather than being based on a and b . Figure 1 shows the angles α and β . The reconstructed unit vector measurement for each star is

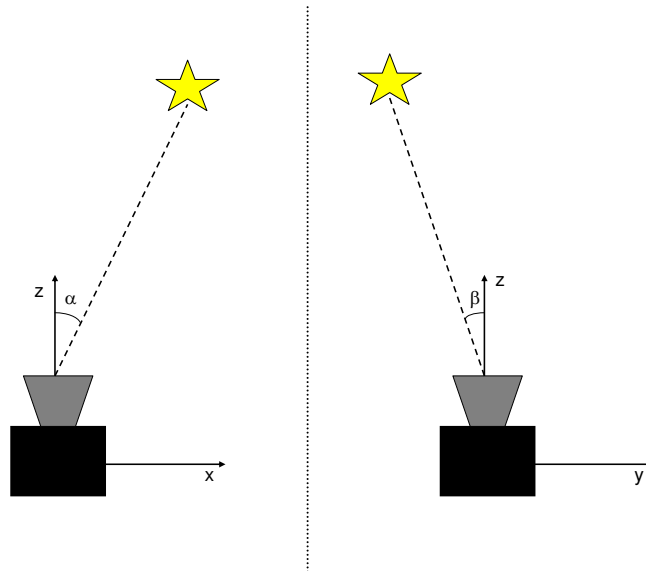

Figure 1 Star camera measured angles.

$$\mathbf{y} = \frac{1}{\sqrt{1 + \tan^2 \alpha + \tan^2 \beta}} \begin{bmatrix} \tan \alpha \\ \tan \beta \\ 1 \end{bmatrix}.$$

Perturbing the angles, it follows that

$$\hat{\mathbf{y}} = \frac{1}{\sqrt{1 + \tan^2(\alpha + \delta\alpha) + \tan^2(\beta + \delta\beta)}} \begin{bmatrix} \tan(\alpha + \delta\alpha) \\ \tan(\beta + \delta\beta) \\ 1 \end{bmatrix}.$$

The vector $\hat{\mathbf{y}}$ can be approximated to first-order as

$$\hat{\mathbf{y}} \simeq \mathbf{y} + \tilde{\mathbf{y}},$$

where

$$\tilde{\mathbf{y}} = \begin{bmatrix} \frac{1+\tan^2 \beta}{(1+\tan^2 \alpha+\tan^2 \beta)^{3/2}} & -\frac{\tan \alpha \tan \beta}{(1+\tan^2 \alpha+\tan^2 \beta)^{3/2}} \\ -\frac{\tan \alpha \tan \beta}{(1+\tan^2 \alpha+\tan^2 \beta)^{3/2}} & \frac{1+\tan^2 \alpha}{(1+\tan^2 \alpha+\tan^2 \beta)^{3/2}} \\ -\frac{\tan \alpha}{(1+\tan^2 \alpha+\tan^2 \beta)^{3/2}} & -\frac{\tan \beta}{(1+\tan^2 \alpha+\tan^2 \beta)^{3/2}} \end{bmatrix} \begin{bmatrix} (1+\tan^2 \alpha)\delta\alpha \\ (1+\tan^2 \beta)\delta\beta \end{bmatrix}.$$

It turns out that $y_z \neq 0$ since the field of view is necessary less than 180 degrees. Therefore, it follows that

$$\begin{aligned} \tilde{\mathbf{y}} &= \frac{1}{y_z} \begin{bmatrix} y_z^2 + y_y^2 & -y_x y_y \\ -y_x y_y & y_z^2 + y_x^2 \\ -y_x y_z & -y_y y_z \end{bmatrix} \begin{bmatrix} (y_z^2 + y_x^2)\delta\alpha \\ (y_z^2 + y_y^2)\delta\beta \end{bmatrix} \\ &= \begin{bmatrix} y_z^2 + y_y^2 & -y_x y_y & -y_x y_z \\ -y_x y_y & y_z^2 + y_x^2 & -y_y y_z \\ -y_x y_z & -y_y y_z & y_y^2 + y_x^2 \end{bmatrix} \begin{bmatrix} \frac{y_z^2 + y_x^2}{y_z} \delta\alpha \\ \frac{y_z^2 + y_y^2}{y_z} \delta\beta \\ 0 \end{bmatrix} \\ &= -[\mathbf{y} \times]^2 \begin{bmatrix} \frac{y_z^2 + y_x^2}{y_z} \delta\alpha \\ \frac{y_z^2 + y_y^2}{y_z} \delta\beta \\ 0 \end{bmatrix} = -[\mathbf{y} \times]^2 \mathbf{U} \delta\alpha, \end{aligned}$$

where

$$\mathbf{U} = \begin{bmatrix} \frac{y_z^2 + y_x^2}{y_z} & 0 \\ 0 & \frac{y_z^2 + y_y^2}{y_z} \\ 0 & 0 \end{bmatrix}, \quad \delta\alpha = \begin{bmatrix} \delta\alpha \\ \delta\beta \end{bmatrix}.$$

Therefore

$$\mathbf{R}_y = [\mathbf{y} \times]^2 \mathbf{U} \mathbf{E} \{ \delta\alpha \delta\alpha^T \} \mathbf{U}^T [\mathbf{y} \times]^2.$$

Star catalogs usually provide the right ascension ζ and the declination ξ of the star. Therefore the inertial unit vector pointing to the star is given by

$$\mathbf{n} = [\cos \zeta \cos \xi \quad \sin \zeta \cos \xi \quad \sin \xi]^T.$$

The true azimuth and elevation are unknown, the quantities in the catalog are estimates and contain errors. The estimate of the inertial vector pointing to the star is given by

$$\hat{\mathbf{n}} = \mathbf{n} + \tilde{\mathbf{n}}.$$

To first order, the error $\tilde{\mathbf{n}}$ is given by

$$\tilde{\mathbf{n}} = \left. \frac{\partial \mathbf{n}}{\partial \zeta} \right|_{\hat{\zeta}} \delta\zeta,$$

where $\zeta = [\zeta \quad \xi]^T$, and $\delta\zeta$ are the star catalog errors. Hence

$$\tilde{\mathbf{n}} = \begin{bmatrix} -\sin \hat{\zeta} \cos \hat{\xi} & -\cos \hat{\zeta} \sin \hat{\xi} \\ \cos \hat{\zeta} \cos \hat{\xi} & \sin \hat{\zeta} \sin \hat{\xi} \\ 0 & \cos \hat{\xi} \end{bmatrix} \delta\zeta = \mathbf{W} \delta\zeta,$$

and

$$\mathbf{R}_n = \mathbf{W} \mathbf{E} \{ \delta\zeta \delta\zeta^T \} \mathbf{W}^T.$$

INTRODUCTION OF A PREPROCESSOR IN THE KALMAN FILTER

In this section two approaches to the decentralized attitude navigation problem will be analyzed. The architectures investigated here are filter/sub-filter as shown in Figure 2. In this work we are concerned with a decentralized scheme in which the sub-filter passes only its estimates of the state and the uncertainty. Optimal decentralized schemes exist for which the sub-filter needs also to provide additional quantities, see for example Refs. 24 and 25.

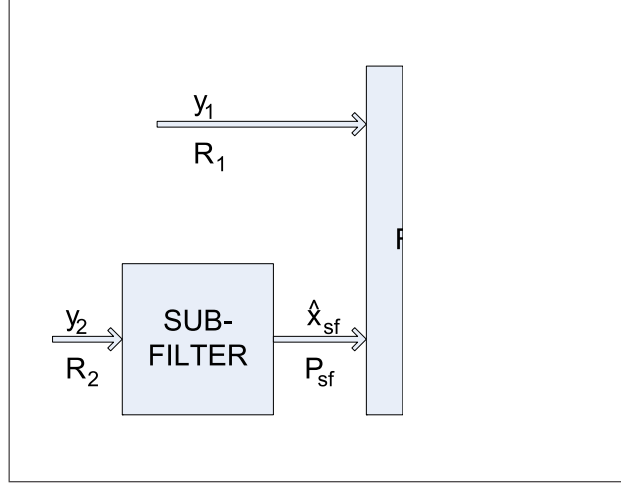

Figure 2 Main filter with raw measurements and a filtered state as inputs.

Uncorrelated Sub-filter

Assume the state vector is partitioned into two components as

$$\mathbf{x}^T = [\mathbf{x}_1^T \quad \mathbf{x}_2^T].$$

Consider that the entire vector measurement can be also partitioned into two components. Vector y_2 is independent of \mathbf{x}_1 , and y_1 is a function of the entire state \mathbf{x} . With the measurement partitioned as

$$\begin{aligned} \mathbf{y}^T &= [y_1^T \quad y_2^T] \\ y_1 &= \mathbf{H}_1 \mathbf{x} + \nu_1, \quad y_2 = \mathbf{H}_2 \mathbf{x}_2 + \nu_2. \end{aligned}$$

At each time t_k when the measurement is available, we have the measurement model

$$\begin{aligned} \mathbf{y}_k &= \mathbf{H}_k \mathbf{x}_k + \nu_k \\ \mathbf{H}_k &= \begin{bmatrix} \mathbf{H}_{1,k} \\ \tilde{\mathbf{H}}_{2,k} \end{bmatrix}, \end{aligned}$$

where

$$\tilde{\mathbf{H}}_{2,k} = [\mathbf{O} \quad \mathbf{H}_{2,k}].$$

Vector ν_k is zero mean white noise with

$$\mathbb{E} \{ \nu_k \nu_j^T \} = \mathbf{R}_k \delta_{kj} \quad \forall k, j.$$

Superscript $-$ denotes the *a priori* value, i.e. the value before the measurement is processed. Superscript $+$ denotes the *a posteriori* value, i.e. the value after the measurement is processed.

The derivation is similar to that used to obtain the recursive Kalman filter from batch estimation. The optimal global information filter update is²⁵

$$(\mathbf{P}^+)^{-1} = (\mathbf{P}^-)^{-1} + \mathbf{H}^T \mathbf{R}^{-1} \mathbf{H} \quad (14)$$

$$\hat{\mathbf{x}}^+ = \mathbf{P}^+ [(\mathbf{P}^-)^{-1} \hat{\mathbf{x}}^- + \mathbf{H}^T \mathbf{R}^{-1} \mathbf{y}], \quad (15)$$

matrix \mathbf{P} being the estimation error covariance. Assuming ν_1 and ν_2 are uncorrelated from each other, i.e.

$$\mathbf{R} = \begin{bmatrix} \mathbf{R}_1 & \mathbf{O} \\ \mathbf{O} & \mathbf{R}_2 \end{bmatrix},$$

Eqs. (14)-(15) become

$$(\mathbf{P}^+)^{-1} = (\mathbf{P}^-)^{-1} + \mathbf{H}_1^T \mathbf{R}_1^{-1} \mathbf{H}_1 + \tilde{\mathbf{H}}_2^T \mathbf{R}_2^{-1} \tilde{\mathbf{H}}_2 \quad (16)$$

$$\hat{\mathbf{x}}^+ = \mathbf{P}^+ \left[(\mathbf{P}^-)^{-1} \hat{\mathbf{x}}^- + \mathbf{H}_1^T \mathbf{R}_1^{-1} \mathbf{y}_1 + \tilde{\mathbf{H}}_2^T \mathbf{R}_2^{-1} \mathbf{y}_2 \right]. \quad (17)$$

We consider the case in which the sub-filter provides estimates based only on the current measurement and not on previous ones, i.e. $\mathbf{P}_{sf}^- = \infty$. Then the sub-filter update is given by

$$\mathbf{P}_{sf}^{-1} = \mathbf{H}_2^T \mathbf{R}_2^{-1} \mathbf{H}_2 \quad (18)$$

$$\hat{\mathbf{x}}_{sf} = \mathbf{P}_{sf} \mathbf{H}_2^T \mathbf{R}_2^{-1} \mathbf{y}_2. \quad (19)$$

Using Eqs. (18)–(19), the update of the central filter given by Eqs. (16)–(17), can be rewritten as

$$\begin{aligned} (\mathbf{P}^+)^{-1} &= (\mathbf{P}^-)^{-1} + \mathbf{H}_1^T \mathbf{R}_1^{-1} \mathbf{H}_1 + [\mathbf{O} \quad \mathbf{I}]^T \mathbf{P}_{sf}^{-1} [\mathbf{O} \quad \mathbf{I}] \\ \hat{\mathbf{x}}^+ &= \mathbf{P}^+ \left\{ (\mathbf{P}^-)^{-1} \hat{\mathbf{x}}^- + \mathbf{H}_1^T \mathbf{R}_1^{-1} \mathbf{y}_1 + [\mathbf{O} \quad \mathbf{I}]^T \mathbf{P}_{sf}^{-1} \hat{\mathbf{x}}_{sf} \right\}. \end{aligned}$$

Therefore, treating the sub-filter as a sensor that measures \mathbf{x}_2 with covariance \mathbf{P}_2 will lead to an optimal linear estimate.

A star-tracker, for example will satisfy all the above assumptions. The stars are practically infinitely far, and therefore the unit vector pointing to them is independent of the spacecraft position. Also star-trackers rely only on the current star measurements to formulate an estimate. Other examples of sensors that satisfy the above hypothesis are some GPS receivers, and more precisely those that use a least square solution of at least four pseudo-ranges to estimate position and clock error. The GPS receivers that contain an IMU and a Kalman filter do not satisfy the above hypothesis.

Like for any Kalman filter application, the optimality does not hold strictly but conditionally to the linearization assumption. The optimality of the previous section was shown for the linear model. Because of the absence of *a priori* information, Eqs. (18) and (19) are the linear least-squares solution. For the nonlinear star-tracker algorithm two solutions are possible. The first is to linearize the problem, by doing so the decentralization of the extended Kalman filter holds strictly. Our preferred solution is to substitute the linearized least-squares formulation with the Davenport-q method, since it is the optimal least-squares solution without any linearization assumptions. Therefore the single Kalman filter and the decentralized filter implementations are not identical. A similar situation arises in Ref 19 when the optimality criteria is maximum likelihood. The Kalman filter is the maximum likelihood estimator under the linearization assumption.

Correlated Sub-Filter and Attitude Sub-Filter Implementation

Generally the measurements processed by a sub-filter may not only depend on its own states. A magnetometer, for example, measures the local magnetic field. Such a measurement is a function of the spacecraft position. If the magnetometer measurement was to be processed in a sub-filter implementing Davenport-q algorithm, the estimated quaternion would be a function of the estimated spacecraft position. If the quaternion estimate obtained through Davenport-q algorithm was processed by the navigation filter as a measurement, this measurement would be correlated to the filter state, and such correlation should be taken into account. Figure 3 shows the architecture of this filter/sub-filter case.

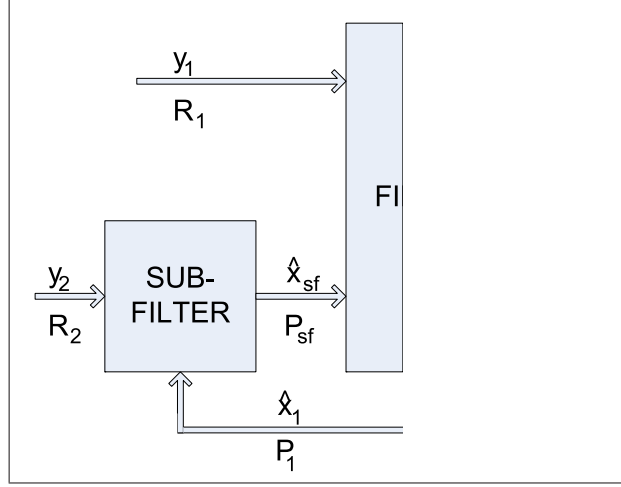

Figure 3 Main filter with raw measurements and a filtered state as inputs.

Using the previous notation, y_2 is now a function of the entire state vector, not of just x_2 . This scheme will not be optimal because y_2 contains information on x_1 that will not be used by the sub-filter. However, it can be made sub-optimal by correctly taking into consideration the correlation. Sub-optimal implies that \hat{x}_2 is globally optimal and \hat{x}_1 is optimal only given y_1 and \hat{x}_2 . The measurement y_2 is modeled as

$$y_2 = \mathbf{H}_2 \mathbf{x} + \nu_2 = \mathbf{H}_{2,1} \mathbf{x}_1 + \mathbf{H}_{2,2} \mathbf{x}_2 + \nu_2.$$

The sub-filter only estimates x_2 , therefore part of the information is ignored, leading to the non-optimality of the estimation of x_1 . The component of the state vector x_1 is modeled by the estimate of x_1 from the central filter. The uncertainty associated with the estimate \hat{x}_1 needs to be added to the measurement noise in order for the sub-filter to be optimal. The estimated measurement is given by

$$\hat{y}_2 = \mathbf{H}_{2,1} \hat{x}_1 + \mathbf{H}_{2,2} \hat{x}_2.$$

The sub-filter only estimates $\mathbf{x}_{sf} = \mathbf{x}_2$. The residual is given by

$$\epsilon = y_2 - \hat{y}_2 = \mathbf{H}_{2,2} \mathbf{e}_{sf} + \mathbf{H}_{2,1} \mathbf{e}_1 + \nu_2.$$

Effectively then, the *measurement* noise of the sub-filter is not only ν_2 , but $\mathbf{H}_{2,1} \mathbf{e}_1 + \nu_2$, where \mathbf{e}_1 is the estimation error of the central filter associated with x_1 . It is assumed that the sub-filter does

not use an *a priori* estimate, i.e. $\mathbf{P}_{sf}^- = \infty$. Using the information formulation, we find that

$$\mathbf{P}_{sf} = \left[\mathbf{H}_{2,2}^T (\mathbf{H}_{2,1} \mathbf{P}_{11} \mathbf{H}_{2,1}^T + \mathbf{R}_2)^{-1} \mathbf{H}_{2,2} \right]^{-1} \quad (20)$$

$$\mathbf{K}_{sf} = \mathbf{P}_{sf} \mathbf{H}_{2,2}^T (\mathbf{H}_{2,1} \mathbf{P}_{11} \mathbf{H}_{2,1}^T + \mathbf{R}_2)^{-1} \quad (21)$$

$$\hat{\mathbf{x}}_{sf} = \mathbf{K} \boldsymbol{\epsilon}, \quad (22)$$

where \mathbf{P}_{11} is the central filter error covariance associated with $\hat{\mathbf{x}}_1$. Since the central filter estimation error of \mathbf{x}_1 affects the estimate of the sub-filter, there will be a correlation between the sub-filter estimate $\hat{\mathbf{x}}_{sf}$ and the central filter estimate $\hat{\mathbf{x}}_1$. The central filter is not going to recover optimality, however sub-optimality can be achieved through the use of the correlation

$$\mathbf{C}_k = \mathbb{E} \left\{ \mathbf{e}_k^- (\mathbf{e}_{sf,k})^T \right\} = \begin{bmatrix} \mathbb{E} \left\{ \mathbf{e}_{1,k}^- (\mathbf{e}_{sf,k})^T \right\} \\ \mathbf{O} \end{bmatrix}.$$

The central filter update equations are

$$\begin{aligned} \mathbf{P}_k^+ &= (\mathbf{I} - \mathbf{K}_k \mathbf{H}_k) \mathbf{P}_k^- (\mathbf{I} - \mathbf{K}_k \mathbf{H}_k)^T + \mathbf{K}_k \mathbf{R}_k \mathbf{K}_k^T - (\mathbf{I} - \mathbf{K}_k \mathbf{H}_k) \mathbf{C}_k \mathbf{K}_k^T \\ &\quad - \mathbf{K}_k \mathbf{C}_k^T (\mathbf{I} - \mathbf{K}_k \mathbf{H}_k)^T \end{aligned} \quad (23)$$

$$\mathbf{K}_k = (\mathbf{H}_k \mathbf{P}_k^- + \mathbf{C}_k^T) (\mathbf{H}_k \mathbf{P}_k^- \mathbf{H}_k^T + \mathbf{R}_k + \mathbf{H}_k \mathbf{C}_k + \mathbf{C}_k^T \mathbf{H}_k^T)^{-1} \quad (24)$$

$$\hat{\mathbf{x}}_k^+ = \hat{\mathbf{x}}_k^- + \mathbf{K}_k (\hat{\mathbf{x}}_{sf,k} - \mathbf{H}_k \hat{\mathbf{x}}_k^-) \quad (25)$$

$$\mathbf{H}_k = \begin{bmatrix} \mathbf{O} & \mathbf{I} \end{bmatrix}. \quad (26)$$

A spacecraft implementing an attitude sub-filter would use this algorithm when some of the inertial reference vectors \mathbf{n}_i are functions of position, such as the magnetometer and horizon sensor. In this attitude sub-filter example, the sub-filter implements Davenport's algorithm to estimate the attitude from the vector measurements. Therefore Eqs. (20)–(22) are not used, but instead are replaced by Eqs. (5) and (10). To compute the inertial reference vectors \mathbf{n}_i , the main filter passes to the sub-filter the position estimate and the position covariance. The sub-filter outputs the quaternion estimate, together with its covariance and the cross-covariance between the sub-filter quaternion estimate and position. The cross-covariance $\mathbf{P}_{r\theta}$ is calculated with Eq. (13). The state vector of the central filter is given by

$$\mathbf{x}^T = [\mathbf{r}^T \quad \mathbf{v}^T \quad \delta \boldsymbol{\alpha}^T],$$

the measurement is given by the sub-filter's quaternion estimate

$$\bar{\mathbf{y}} = \hat{q}_{sf}.$$

The central filter uses Eqs. (23)–(26) to update the state, the only difference is that replaces the additive residual $\hat{\mathbf{x}}_{sf} - \mathbf{H} \hat{\mathbf{x}}^-$ with twice the vector part of the multiplicative residual $\delta \bar{\mathbf{y}}$

$$\delta \bar{\mathbf{y}} = \hat{q}_{sf} \otimes (\hat{q}^-)^{-1}.$$

The correlation \mathbf{C} between the measurement and the state is given by

$$\mathbf{C} = \begin{bmatrix} \mathbf{P}_{r\theta} \\ \mathbf{O}_{6 \times 3} \end{bmatrix}.$$

LUNAR DESCENT TO LANDING NAVIGATION

The technique previously developed will be applied to a problem of much current interest: lunar descent to landing navigation. The scenario considered here begins after the conclusion of the orbital phase when the descent trajectory begins. The descent trajectory is thrust-coast-thrust. The propulsion system initiates the descent, followed by a no thrust phase. When a predetermined altitude is reached, the propulsion system will be employed to land the spacecraft. The available sensors are an altimeter, a velocimeter, together with a star camera and a strapdown IMU. The altimeter provides a measurement of altitude along the local vertical, and the velocimeter measures relative velocity with respect to Moon surface. The models for these sensors, together with the true trajectory, are those used in Ref. 26. Figures 4 and 5 show the true trajectory. Figure 6 shows the measurement times for each external sensor. The IMU is providing measurements at 40 Hertz.

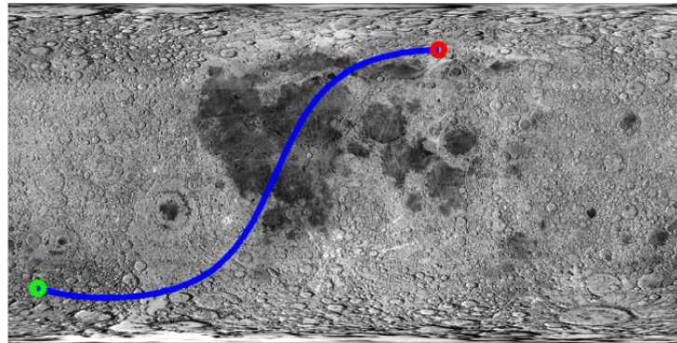

Figure 4 Groundtrack of lunar descent to landing trajectory. Green dot is the starting point, red dot the end point.

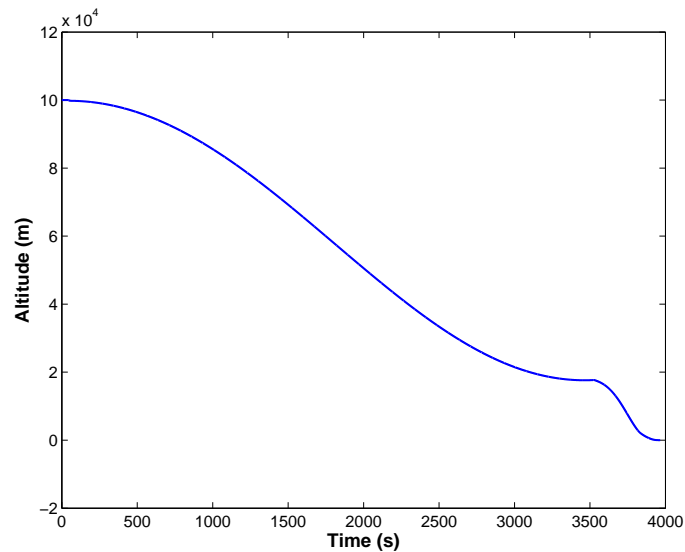

Figure 5 Altitude of lunar descent to landing trajectory..

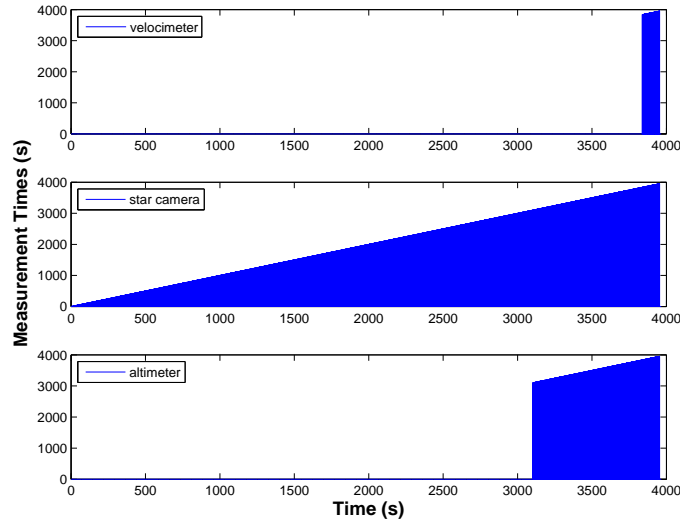

Figure 6 Times for external measurements.

Extended Kalman Filter

This section introduces the Kalman filter used to process the altimeter, velocimeter, and gyro measurements, together with the quaternion “measurement” provided by the star camera. The accelerometer is dead-reckoned and used to propagate the state vector.

The state propagation consists of numerically integrating the model

$$\frac{d}{dt} \begin{bmatrix} \hat{\mathbf{r}} \\ \hat{\mathbf{v}} \\ \hat{\mathbf{q}} \end{bmatrix} = \begin{bmatrix} \hat{\mathbf{v}} \\ \mathbf{g}(\hat{\mathbf{r}}) + \mathbf{T}(\hat{\mathbf{q}})^T \mathbf{a}_m \\ \frac{1}{2} \bar{\boldsymbol{\omega}}_m \otimes \hat{\mathbf{q}} \end{bmatrix}$$

where $\bar{\boldsymbol{\omega}}_m$ is a pure quaternion with vector component $\boldsymbol{\omega}_m$, vectors $\boldsymbol{\omega}_m$ and \mathbf{a}_m are the IMU measurements. The components of the estimation error are defined as

$$\mathbf{e}_r \triangleq \mathbf{r} - \hat{\mathbf{r}}, \quad \mathbf{e}_v \triangleq \mathbf{v} - \hat{\mathbf{v}}, \quad \mathbf{e}_\theta \triangleq 2\delta\mathbf{q},$$

where $\delta\mathbf{q}$ is the vector component of $\delta\bar{\mathbf{q}} \triangleq \bar{\mathbf{q}} \otimes \hat{\mathbf{q}}^{-1}$. The first-order approximation of the evolution of the velocity and attitude components of the error is

$$\begin{aligned} \dot{\mathbf{e}}_v &= \mathbf{G}(\hat{\mathbf{r}})\mathbf{e}_r + \mathbf{T}(\hat{\mathbf{q}})^T[\mathbf{e}_\theta \times] \mathbf{a}_m - \mathbf{T}(\hat{\mathbf{q}})^T \boldsymbol{\eta}_a + \boldsymbol{\nu}_g \\ \dot{\mathbf{e}}_\theta &= -[\boldsymbol{\omega}_m \times] \mathbf{e}_\theta + \boldsymbol{\eta}_\omega, \end{aligned}$$

where $\boldsymbol{\eta}_a$ and $\boldsymbol{\eta}_\omega$ are the IMU errors, and $\boldsymbol{\nu}_g$ is the difference between the true and the modeled gravitational acceleration. The evolution of the estimation error can then be written in compact matrix form

$$\dot{\mathbf{e}} = \mathbf{F}\mathbf{e} + \boldsymbol{\nu},$$

where

$$\mathbf{F} \triangleq \begin{bmatrix} \mathbf{O}_{3 \times 3} & \mathbf{I}_{3 \times 3} & \mathbf{O}_{3 \times 3} \\ \mathbf{G}(\hat{\mathbf{r}}) & \mathbf{O}_{3 \times 3} & -\mathbf{T}(\hat{\mathbf{q}})^T[\mathbf{a}_m \times] \\ \mathbf{O}_{3 \times 3} & \mathbf{O}_{3 \times 3} & -[\boldsymbol{\omega}_m \times] \end{bmatrix},$$

and

$$\boldsymbol{\nu} = \begin{bmatrix} \mathbf{0} \\ -\mathbf{T}(\hat{\boldsymbol{q}})^{\mathbf{T}} \boldsymbol{\eta}_a + \boldsymbol{\nu}_g \\ \boldsymbol{\eta}_\omega \end{bmatrix} \quad \mathbb{E}\{\boldsymbol{\nu}(t)\} = \mathbf{0} \quad \mathbb{E}\{\boldsymbol{\nu}(t)\boldsymbol{\nu}^{\mathbf{T}}(\tau)\} = \mathbf{Q}(t)\delta(t-\tau).$$

Between measurements, the covariance propagation is given by the continuous-time Riccati equation

$$\dot{\mathbf{P}}(t) = \mathbf{F}(\hat{\mathbf{x}})\mathbf{P}(t) + \mathbf{P}(t)\mathbf{F}(\hat{\mathbf{x}})^{\mathbf{T}} + \mathbf{Q}(t).$$

where $\mathbf{P}(t) = \mathbb{E}\{\mathbf{e}\mathbf{e}^{\mathbf{T}}\}$, and assuming the initial estimation error is zero-mean.

The state is updated using altimeter, velocimeter and the quaternion star camera as measurements. The star tracker provides an estimate of the quaternion \hat{q}_{st} and the associated estimation uncertainty given by the small angle covariance \mathbf{P}_{st} . Since the star tracker formulates its estimates based only on the current measurements, it was shown that is optimal to treat the star tracker as a measurement and its covariance as measurement noise. However, deviations rather than quaternions are used. The processed measurement is twice the vector part of the deviation between the ‘‘measured’’ quaternion \hat{q}_{st} and the nominal quaternion \hat{q}^- at time t_k . The deviation is given by

$$\bar{\mathbf{y}}_{st,k} = \hat{q}_{st,k} \otimes (\hat{q}_k^-)^{-1}.$$

The estimated measurement is zero, therefore the star tracker residual $\boldsymbol{\epsilon}_{st,k}$

$$\boldsymbol{\epsilon}_{st,k} = 2\mathbf{y}_{st,k}.$$

The state vector for update purposes is given by

$$\mathbf{x}_k^{\mathbf{T}} = \begin{bmatrix} \hat{\mathbf{r}}_k^{\mathbf{T}} & \hat{\mathbf{v}}_k^{\mathbf{T}} & \delta\hat{\boldsymbol{\theta}}_k^{\mathbf{T}} \end{bmatrix}, \quad \delta\hat{\boldsymbol{\theta}}_k^- = \mathbf{0}.$$

The star tracker measurement mapping matrix is,

$$\mathbf{H}_{st,k} = \begin{bmatrix} \mathbf{O}_{3 \times 6} & \mathbf{I}_{3 \times 3} \end{bmatrix}.$$

If other measurements are available at time t_k , they would be included as

$$\boldsymbol{\epsilon}_k = \begin{bmatrix} \boldsymbol{\epsilon}_{st,k} \\ \boldsymbol{\epsilon}_{others,k} \end{bmatrix} \quad \mathbf{H}_k = \begin{bmatrix} \mathbf{H}_{st,k} \\ \mathbf{H}_{others,k} \end{bmatrix} \quad \mathbf{R}_k = \begin{bmatrix} \mathbf{P}_{st,k} & \mathbf{O} \\ \mathbf{O} & \mathbf{R}_{others,k} \end{bmatrix},$$

assuming the other measurements are uncorrelated to the star camera’s.

The residuals covariance is given by

$$\mathbf{W}_k = \mathbf{H}_k \mathbf{P}_k^- \mathbf{H}_k^{\mathbf{T}} + \mathbf{R}_k,$$

the standard Kalman filter update is

$$\mathbf{K}_k = \mathbf{P}_k \mathbf{H}_k^{\mathbf{T}} \mathbf{W}_k^{-1}, \quad \hat{\mathbf{x}}_k^+ = \hat{\mathbf{x}}_k^- + \mathbf{K}_k \boldsymbol{\epsilon}_k, \quad \mathbf{P}_k^+ = \mathbf{P}_k^- - \mathbf{K}_k \mathbf{W}_k \mathbf{K}_k^{\mathbf{T}}.$$

The quaternion update is

$$\hat{q}^+ = \begin{bmatrix} \frac{1}{2} \delta\hat{\boldsymbol{\theta}}^+ \\ 1 \end{bmatrix} \otimes \hat{q}^-,$$

followed by the normalization to restore the unit norm constraint.

Simulation Results

In this section the results of one hundred runs will be presented. The analysis shows that statistical properties of the estimation error are appropriately represented by the filter covariance. Table 1 shows the standard deviations of the measurement errors generated in the simulation.

Accelerometer Noise	10 [$\mu g\sqrt{s}$]
Accelerometer Bias	1 [μg]
Accelerometer Scale Factor	175 [ppm]
Accelerometer Misalignment	5 [$arcsec$]
Gyro Noise	0.01 [deg/\sqrt{hr}]
Gyro Bias	0.001 [deg/hr]
Gyro Scale Factor	5 [ppm]
Gyro Misalignment	5 [$arcsec$]
Altimeter Noise	10 [m]
Altimeter Bias	0.5 [m]
Velocimeter Noise	0.5 [m/s]
Velocimeter Bias	0.05 [m/s]
Star Camera Noise	50 [$arcsec$]

Table 1 Random error standard deviation values

Figures 7–9 plot the filter covariance (black line) and the sample covariance from the runs (blue line). Each run implements different initial estimation error and measurement errors. Figure 10 shows the Monte Carlo analysis of the star camera estimate and covariance. The filter covariance clearly shows the time at which the altimeter starts providing measurements (approximately 3200 seconds), and the time at which the velocimeter start providing measurements (approximately 3800 seconds). It can be also noticed that the y component of position is not very observable. This fact is due to its orientation perpendicular to the trajectory. In order to make the y component of position more observable, it is necessary to introduce an additional measurement related to position, like a range measurement (in an appropriate direction) or a full three dimensional position measurement deduced from a terrain camera.

CONCLUSIONS

A study of precision navigation to support landing on the Moon was performed. Particular attention was given to the inclusion of the attitude estimation into the Kalman filter. The processing of attitude estimates as if they were raw measurements was analyzed, circumstances in which this approach leads to optimal versus sub-optimal estimates were presented. It was found that a star camera can be optimally fused into a Kalman filter without requiring any particular distribution of the measurement noise. As in all extended Kalman filter applications, the optimality holds for the linearized system. The classical Davenport q-algorithm was discussed. This algorithm is to be used by the star camera to produce its estimate. In order to be optimally coupled with the Kalman filter, the star camera needs to provide together with the estimate of the quaternion, an error covariance. A new covariance formulation was introduced and utilized in the study.

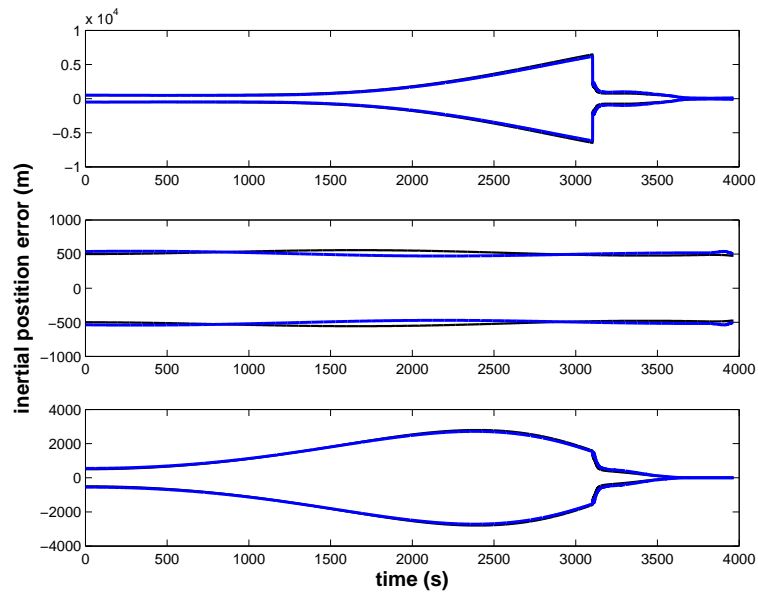

Figure 7 Monte Carlo analysis of position estimation error.

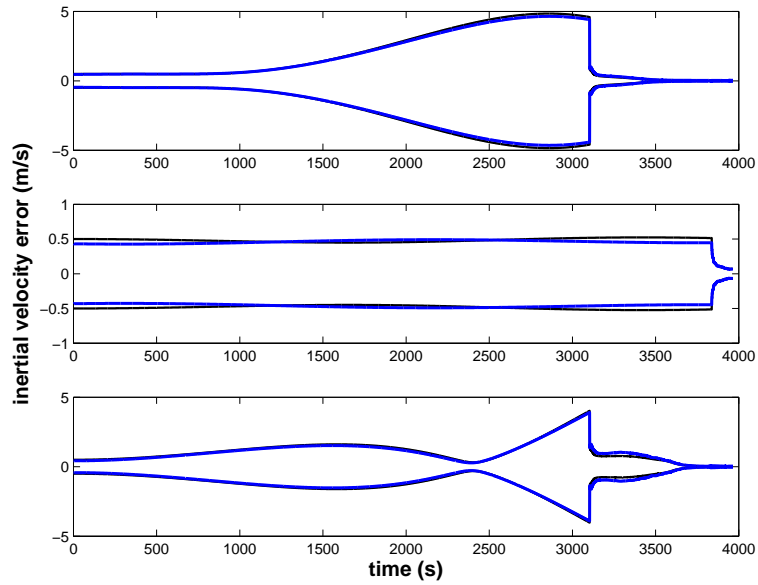

Figure 8 Monte Carlo analysis of velocity estimation error.

REFERENCES

- [1] R. E. Kalman, "A New Approach to Linear Filtering and Prediction Problems," *Journal of Basic Engineering*, March 1960, pp. 35–45.
- [2] R. E. Kalman and R. S. Bucy, "New Results in Linear Filtering and Prediction," *Journal of Basic Engineering*, 1961, pp. 83–95.
- [3] A. Gelb, ed., *Applied Optimal Estimation*. Cambridge, MA: The MIT press Massachusetts Institute of Technology, 1996.
- [4] J. Stuelpnagel, "On the Parametrization of the Three-Dimensional Rotation Group," *SIAM Review*, Vol. 6, Oct 1964, pp. 422–430.

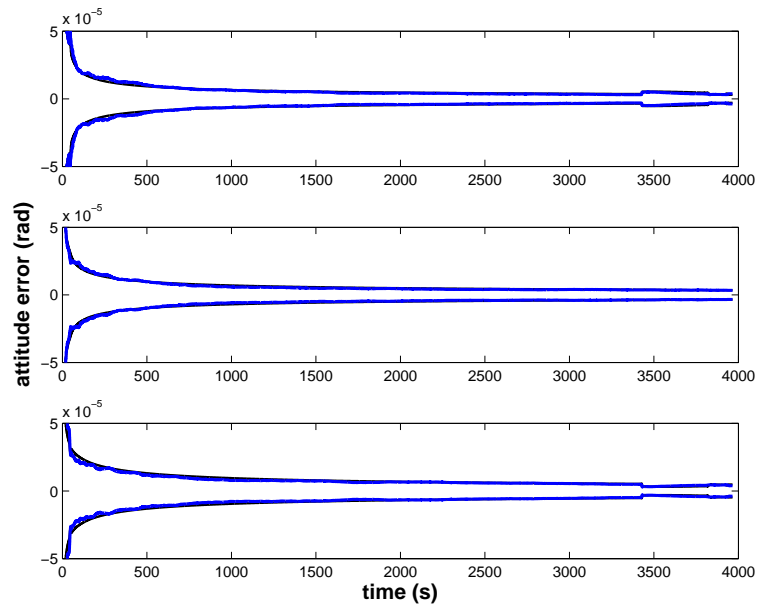

Figure 9 Monte Carlo analysis of attitude estimation error.

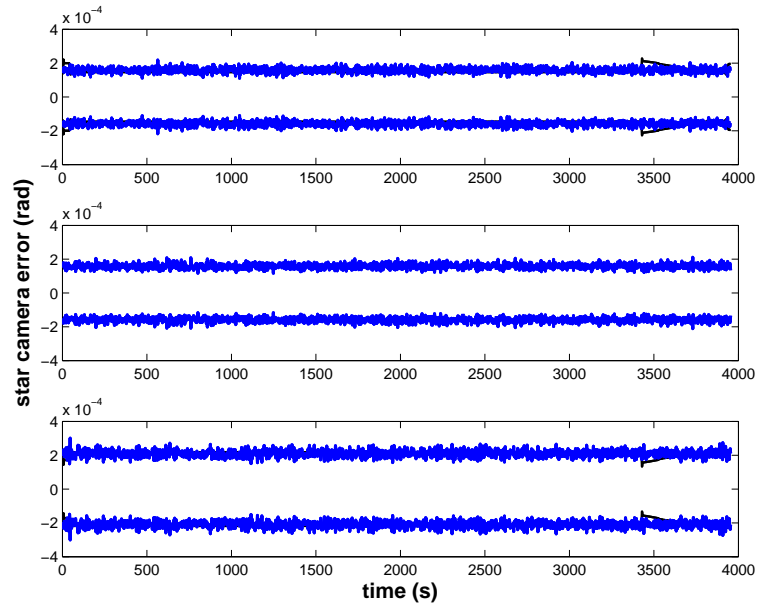

Figure 10 Monte Carlo analysis of star camera estimation error.

- [5] J. B. Kuipers, *Quaternions and Rotation Sequences*. Princeton, NJ: Princeton University Press, 1999.
- [6] M. D. Shuster, "Constraint in Attitude Estimation: Part I Constrained Estimation," *The Journal of the Astronautical Sciences*, Vol. 51, January-March 2003, pp. 51–74.
- [7] M. D. Shuster, "Constraint in Attitude Estimation: Part II Unconstrained Estimation," *The Journal of the Astronautical Sciences*, Vol. 51, January-March 2003, pp. 75–101.
- [8] I. Y. Bar-Itzhack and Y. Oshman, "Attitude Determination from Vector Observations: Quaternion Estimation," *IEEE Transaction on Aerospace and Electronic Systems*, Vol. 21, January 1985, pp. 128–135.
- [9] J. L. Crassidis and J. L. Junkins, *Optimal Estimation of Dynamic Systems*. Applied Mathematics and Nonlinear Science, Chapman & Hall/VRV, first ed., 2004.

- [10] M. Pittelkau, "An Analysis of the Quaternion Attitude Determination Filter," *Journal of the Astronautical Sciences*, Vol. 51, January-March 2003, pp. 103–120.
- [11] J. E. Keat, "Analysis of Least-Squares Attitude Determination Routine DOAOP," Tech. Rep. CSC/TM-77/6034, Computer Sciences Corporation, February 1977.
- [12] M. D. Shuster, "Maximum Likelihood Estimation of Spacecraft Attitude," *The Journal of the Astronautical Sciences*, Vol. 37, January-March 1989, pp. 79–88.
- [13] J. R. Wertz, ed., *Spacecraft Attitude Determination and Control*. Springer, 1978.
- [14] J. Thienel and R. M. Sanner, "A Coupled Nonlinear Spacecraft Attitude Controller and Observer With an Unknown Constant Gyro Bias and Gyro Noise," *IEEE Transactions on Automatic Control*, Vol. 48, November 2003, pp. 2011–2015.
- [15] M. R. Akella, D. Seo, and R. Zanetti, "Attracting Manifolds for Attitude Estimation in Flatland and Otherlands," *The Journal of the Astronautical Sciences*, Vol. 54, July–December 2006, pp. 635–655.
- [16] M. L. Psiaki, "Attitude-Determination Filtering via Extended Quaternion Estimation," *Journal of Guidance Control and Dynamics*, Vol. 23, March–April 2000, pp. 206–214.
- [17] B. D. Tapley, B. E. Schutz, and G. H. Born, *Statistical Orbit Determination*. Elsevier Academic Press, 2004.
- [18] A. H. Jazwinski, *Stochastic Processes and Filtering Theory*, Vol. 64 of *Mathematics in Sciences and Engineering*. New York, New York 10003: Academic Press, 1970.
- [19] M. D. Shuster, "Kalman Filtering of Spacecraft Attitude and the QUEST Model," *The Journal of the Astronautical Sciences*, Vol. 38, July–September 1990, pp. 377–393.
- [20] G. Casella and R. L. Berger, *Statistical Inference*. Pacific Grove, CA: Duxbury, second ed., 2002.
- [21] G. Wahba, "A least Square Estimate of Satellite Attitude," *SIAM Review*, Vol. 7, July 1965, p. 409. Problem 65-1.
- [22] M. D. Shuster and S. D. Oh, "Three-Axis Attitude Determination from Vector Observations," *Journal of Guidance and Control*, Vol. 4, No. 1, 1981, pp. 70–77.
- [23] Y. Cheng, J. L. Crassidis, and F. L. Markley, "Attitude Estimation for Large Field-of-View Sensors," *The Journal of the Astronautical Sciences*, Vol. 54, July–December 2006, pp. 433–448.
- [24] A. S. Willsky, M. G. Bello, D. A. Castanon, B. C. Levy, and G. C. Verghese, "Combining and Updating of Local Estimates and Regional Maps Along Sets of One-Dimensional Tracks," *IEEE Transactions on Automatic Control*, Vol. AC-27, No. 4, 1982, pp. 799–813.
- [25] R. G. Brown and P. Y. Hwang, *Introduction To Random Signals And Applied Kalman Filtering*. John Wiley and Sons, third ed., 1997.
- [26] K. J. DeMars and R. H. Bishop, "Precision Descent Navigation for Landing at the Moon," *AAS/AIAA Astrodynamics Specialist Conference*, Mackinac Island, MI, August 19–23 2007.