



# Standard Test Method for Flexural Strength of Advanced Ceramics at Ambient Temperature<sup>1</sup>

This standard is issued under the fixed designation C1161; the number immediately following the designation indicates the year of original adoption or, in the case of revision, the year of last revision. A number in parentheses indicates the year of last reapproval. A superscript epsilon ( $\epsilon$ ) indicates an editorial change since the last revision or reapproval.

*This standard has been approved for use by agencies of the Department of Defense.*

## 1. Scope

1.1 This test method covers the determination of flexural strength of advanced ceramic materials at ambient temperature. Four-point– $1/4$  point and three-point loadings with prescribed spans are the standard as shown in Fig. 1. Rectangular specimens of prescribed cross-section sizes are used with specified features in prescribed specimen-fixture combinations. Test specimens may be 3 by 4 by 45 to 50 mm in size that are tested on 40 mm outer span four-point or three-point fixtures. Alternatively, test specimens and fixture spans half or twice these sizes may be used. The method permits testing of machined or as-fired test specimens. Several options for machining preparation are included: application matched machining, customary procedure, or a specified standard procedure. This method describes the apparatus, specimen requirements, test procedure, calculations, and reporting requirements. The test method is applicable to monolithic or particulate- or whisker-reinforced ceramics. It may also be used for glasses. It is not applicable to continuous fiber-reinforced ceramic composites.

1.2 The values stated in SI units are to be regarded as the standard. The values given in parentheses are for information only.

1.3 *This standard does not purport to address all of the safety concerns, if any, associated with its use. It is the responsibility of the user of this standard to establish appropriate safety and health practices and determine the applicability of regulatory limitations prior to use.*

## 2. Referenced Documents

### 2.1 ASTM Standards:<sup>2</sup>

[E4 Practices for Force Verification of Testing Machines](#)

<sup>1</sup> This test method is under the jurisdiction of ASTM Committee C28 on Advanced Ceramics and is the direct responsibility of Subcommittee C28.01 on Mechanical Properties and Performance.

Current edition approved Aug. 1, 2013. Published September 2013. Originally approved in 1990. Last previous edition approved in 2008 as C1161–02c (2008) <sup>$\epsilon$ 1</sup>. DOI: 10.1520/C1161-13

<sup>2</sup> For referenced ASTM standards, visit the ASTM website, [www.astm.org](http://www.astm.org), or contact ASTM Customer Service at [service@astm.org](mailto:service@astm.org). For *Annual Book of ASTM Standards* volume information, refer to the standard's Document Summary page on the ASTM website.

[C1239 Practice for Reporting Uniaxial Strength Data and Estimating Weibull Distribution Parameters for Advanced Ceramics](#)

[C1322 Practice for Fractography and Characterization of Fracture Origins in Advanced Ceramics](#)

[C1368 Test Method for Determination of Slow Crack Growth Parameters of Advanced Ceramics by Constant Stress-Rate Strength Testing at Ambient Temperature](#)

[E337 Test Method for Measuring Humidity with a Psychrometer \(the Measurement of Wet- and Dry-Bulb Temperatures\)](#)

### 2.2 Military Standard:

[MIL-STD-1942 \(MR\) Flexural Strength of High Performance Ceramics at Ambient Temperature<sup>3</sup>](#)

## 3. Terminology

### 3.1 Definitions:

3.1.1 *complete gage section, n*—the portion of the specimen between the two outer bearings in four-point flexure and three-point flexure fixtures.

NOTE 1—In this standard, the complete four-point flexure gage section is twice the size of the inner gage section. Weibull statistical analysis only includes portions of the specimen volume or surface which experience tensile stresses.

3.1.2 *flexural strength*—a measure of the ultimate strength of a specified beam in bending.

3.1.3 *four-point– $1/4$  point flexure*—configuration of flexural strength testing where a specimen is symmetrically loaded at two locations that are situated one quarter of the overall span, away from the outer two support bearings (see Fig. 1).

3.1.4 *Fully-articulating fixture, n*—a flexure fixture designed to be used either with flat and parallel specimens or with uneven or nonparallel specimens. The fixture allows full independent articulation, or pivoting, of all rollers about the specimen long axis to match the specimen surface. In addition, the upper or lower pairs are free to pivot to distribute force evenly to the bearing cylinders on either side.

<sup>3</sup> Available from Standardization Documents Order Desk, DODSSP, Bldg. 4, Section D, 700 Robbins Ave., Philadelphia, PA 19111-5098, <http://www.dodssp.daps.mil>.

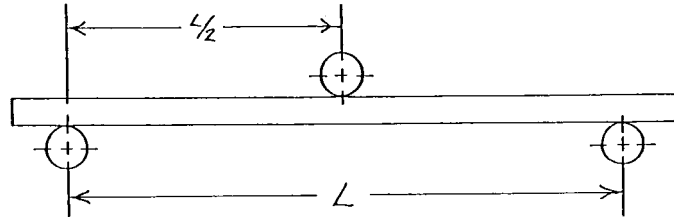
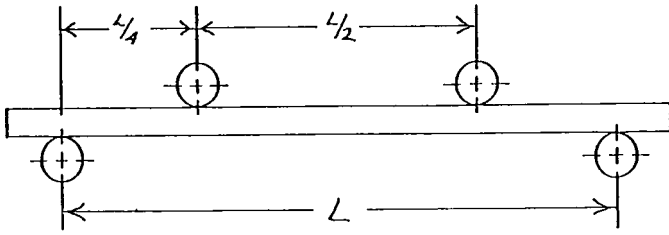

NOTE 1—Configuration:

A:  $L = 20 \text{ mm}$

B:  $L = 40 \text{ mm}$

C:  $L = 80 \text{ mm}$

**FIG. 1 The Four-Point- $\frac{1}{4}$  Point and Three-Point Fixture Configuration**

NOTE 2—See Annex A1 for schematic illustrations of the required pivoting movements.

NOTE 3—A three-point fixture has the inner pair of bearing cylinders replaced by a single bearing cylinder.

3.1.5 *inert flexural strength,  $n$* —a measure of the strength of specified beam in bending as determined in an appropriate inert condition whereby no slow crack growth occurs.

NOTE 4—An inert condition may be obtained by using vacuum, low temperatures, very fast test rates, or any inert media.

3.1.6 *inherent flexural strength,  $n$* —the flexural strength of a material in the absence of any effect of surface grinding or other surface finishing process, or of extraneous damage that may be present. The measured inherent strength is in general a function of the flexure test method, test conditions, and specimen size.

3.1.7 *inner gage section,  $n$* —the portion of the specimen between the inner two bearings in a four-point flexure fixture.

3.1.8 *Semi-articulating fixture,  $n$* —a flexure fixture designed to be used with flat and parallel specimens. The fixture allows some articulation, or pivoting, to ensure the top pair (or bottom pair) of bearing cylinders pivot together about an axis parallel to the specimen long axis, in order to match the specimen surfaces. In addition, the upper or lower pairs are free to pivot to distribute force evenly to the bearing cylinders on either side.

NOTE 5—See Annex A1 for schematic illustrations of the required pivoting movements.

NOTE 6—A three-point fixture has the inner pair of bearing cylinders replaced by a single bearing cylinder.

3.1.9 *slow crack growth (SCG),  $n$* —subcritical crack growth (extension) which may result from, but is not restricted to, such

mechanisms as environmentally-assisted stress corrosion or diffusive crack growth.

3.1.10 *three-point flexure*—configuration of flexural strength testing where a specimen is loaded at a location midway between two support bearings (see Fig. 1).

#### 4. Significance and Use

4.1 This test method may be used for material development, quality control, characterization, and design data generation purposes. This test method is intended to be used with ceramics whose strength is 50 MPa (~7 ksi) or greater.

4.2 The flexure stress is computed based on simple beam theory with assumptions that the material is isotropic and homogeneous, the moduli of elasticity in tension and compression are identical, and the material is linearly elastic. The average grain size should be no greater than one fiftieth of the beam thickness. The homogeneity and isotropy assumption in the standard rule out the use of this test for continuous fiber-reinforced ceramics.

4.3 Flexural strength of a group of test specimens is influenced by several parameters associated with the test procedure. Such factors include the loading rate, test environment, specimen size, specimen preparation, and test fixtures. Specimen sizes and fixtures were chosen to provide a balance between practical configurations and resulting errors, as discussed in MIL-STD 1942 (MR) and Refs (1) and (2).<sup>4</sup> Specific fixture and specimen configurations were designated in order to permit ready comparison of data without the need for Weibull-size scaling.

4.4 The flexural strength of a ceramic material is dependent on both its inherent resistance to fracture and the size and severity of flaws. Variations in these cause a natural scatter in test results for a sample of test specimens. Fractographic analysis of fracture surfaces, although beyond the scope of this standard, is highly recommended for all purposes, especially if the data will be used for design as discussed in MIL-STD-1942 (MR) and Refs (2-5) and Practices C1322 and C1239.

4.5 The three-point test configuration exposes only a very small portion of the specimen to the maximum stress. Therefore, three-point flexural strengths are likely to be much greater than four-point flexural strengths. Three-point flexure has some advantages. It uses simpler test fixtures, it is easier to adapt to high temperature and fracture toughness testing, and it is sometimes helpful in Weibull statistical studies. However, four-point flexure is preferred and recommended for most characterization purposes.

4.6 This method determines the flexural strength at ambient temperature and environmental conditions. The flexural strength under ambient conditions may or may not necessarily be the inert flexural strength.

NOTE 7—time dependent effects may be minimized through the use of inert testing atmosphere such as dry nitrogen gas, oil, or vacuum. Alternatively, testing rates faster than specified in this standard may be

<sup>4</sup> The boldface numbers in parentheses refer to the references at the end of this test method.

used. Oxide ceramics, glasses, and ceramics containing boundary phase glass are susceptible to slow crack growth even at room temperature. Water, either in the form of liquid or as humidity in air, can have a significant effect, even at the rates specified in this standard. On the other hand, many ceramics such as boron carbide, silicon carbide, aluminum nitride and many silicon nitrides have no sensitivity to slow crack growth at room temperature and the flexural strength in laboratory ambient conditions is the inert flexural strength.

## 5. Interferences

5.1 The effects of time-dependent phenomena, such as stress corrosion or slow crack growth on strength tests conducted at ambient temperature, can be meaningful even for the relatively short times involved during testing. Such influences must be considered if flexure tests are to be used to generate design data. Slow crack growth can lead a rate dependency of flexural strength. The testing rate specified in this standard may or may not produce the inert flexural strength whereby negligible slow crack growth occurs. See Test Method **C1368**.

5.2 Surface preparation of test specimens can introduce machining microcracks which may have a pronounced effect on flexural strength. Machining damage imposed during specimen preparation can be either a random interfering factor, or an inherent part of the strength characteristic to be measured. With proper care and good machining practice, it is possible to obtain fractures from the material's natural flaws. Surface preparation can also lead to residual stresses. Universal or standardized test methods of surface preparation do not exist. It should be understood that final machining steps may or may not negate machining damage introduced during the early course or intermediate machining.

5.3 This test method allows several options for the machining of specimens, and includes a general procedure ("Standard" procedure, 7.2.4), which is satisfactory for many (but certainly not all) ceramics. The general procedure used progressively finer longitudinal grinding steps that are designed to minimize subsurface microcracking. Longitudinal grinding aligns the most severe subsurface microcracks parallel to the specimen tension stress axis. This allows a greater opportunity to measure the inherent flexural strength or "potential strength" of the material as controlled by the material's natural flaws. In contrast, transverse grinding aligns the severest subsurface machining microcracks perpendicular to the tension stress axis and the specimen is more likely to fracture from the machining microcracks. Transverse-ground specimens in many instances may provide a more "practical strength" that is relevant to machined ceramic components whereby it may not be possible to favorably align the machining direction. Transverse-ground specimens may be tested in accordance with 7.2.2. Data from transverse-ground specimens may correlate better with data from biaxial disk or plate strength tests, wherein machining direction cannot be aligned.

## 6. Apparatus

6.1 *Loading*—Specimens may be loaded in any suitable testing machine provided that uniform rates of direct loading can be maintained. The force-measuring system shall be free of initial lag at the loading rates used and shall be equipped with a means for retaining read-out of the maximum force applied to

the specimen. The accuracy of the testing machine shall be in accordance with Practices **E4** but within 0.5 %.

6.2 *Four-Point Flexure*—Four-point- $\frac{1}{4}$  point fixtures (**Fig. 1**) shall have support and loading spans as shown in **Table 1**.

6.3 *Three-Point Flexure*—Three-point fixtures (**Fig. 1**) shall have a support span as shown in **Table 1**.

6.4 *Bearings*—Three- and four-point flexure:

6.4.1 Cylindrical bearing edges shall be used for the support of the test specimen and for the application of load. The cylinders shall be made of hardened steel which has a hardness no less than HRC 40 or which has a yield strength no less than 1240 MPa (~180 ksi). Alternatively, the cylinders may be made of a ceramic with an elastic modulus between 2.0 and 4.0  $\times 10^5$  MPa (30–60  $\times 10^6$  psi) and a flexural strength no less than 275 MPa (~40 ksi). The portions of the test fixture that support the bearings may need to be hardened to prevent permanent deformation. The cylindrical bearing length shall be at least three times the specimen width. The above requirements are intended to ensure that ceramics with strengths up to 1400 MPa (~200 ksi) and elastic moduli as high as 4.8  $\times 10^5$  MPa (70  $\times 10^6$  psi) can be tested without fixture damage. Higher strength and stiffer ceramic specimens may require harder bearings.

6.4.2 The bearing cylinder diameter shall be approximately 1.5 times the beam depth of the test specimen size employed. See **Table 2**.

6.4.3 The bearing cylinders shall be carefully positioned such that the spans are accurate within  $\pm 0.10$  mm. The load application bearing for the three-point configurations shall be positioned midway between the support bearing within  $\pm 0.10$  mm. The load application (inner) bearings for the four-point configurations shall be centered with respect to the support (outer) bearings within  $\pm 0.10$  mm.

6.4.4 The bearing cylinders shall be free to rotate in order to relieve frictional constraints (with the exception of the middle-load bearing in three-point flexure which need not rotate). This can be accomplished by mounting the cylinders in needle bearing assemblies, or more simply by mounting the cylinders as shown in **Fig. 2** and **Fig. 3**. **Annex A1** illustrates the action required of the bearing cylinders. Note that the outer-support bearings roll *outward* and the inner-loading bearings roll *inward*.

6.5 *Semiarticulating-Four-Point Fixture*—Specimens prepared in accordance with the parallelism requirements of 7.1 may be tested in a semiarticulating fixture as illustrated in **Fig. 2** and in **Fig. A1.1a**. All four bearings shall be free to roll. The two inner bearings shall be parallel to each other to within 0.015 mm over their length and they shall articulate together as a pair. The two outer bearings shall be parallel to each other to within 0.015 mm over their length and they shall articulate together as a pair. The inner bearings shall be supported

**TABLE 1 Fixture Spans**

Configuration	Support Span (L), mm	Loading Span, mm
A	20	10
B	40	20
C	80	40

**TABLE 2 Nominal Bearing Diameters**

Configuration	Diameter, mm
A	2.0 to 2.5
B	4.5
C	9.0

independently of the outer bearings. All four bearings shall rest uniformly and evenly across the specimen surfaces. The fixture shall be designed to apply equal load to all four bearings.

**6.6 Fully Articulating—Four-Point Fixture**—Specimens that are as-fired, heat treated, or oxidized often have slight twists or unevenness. Specimens which do not meet the parallelism requirements of 7.1 shall be tested in a fully articulating fixture as illustrated in Fig. 3 and in Fig. A1.1b. Well-machined specimens may also be tested in fully-articulating fixtures. All four bearings shall be free to roll. One bearing need not articulate. The other three bearings shall articulate to match the specimen's surface. All four bearings shall rest uniformly and evenly across the specimen surfaces. The fixture shall apply equal load to all four bearings.

**6.7 Semi-articulated Three-point Fixture**—Specimens prepared in accordance with the parallelism requirements of 7.1 may be tested in a semiarticulating fixture. The middle bearing shall be fixed and not free to roll. The two outer bearings shall be parallel to each other to within 0.015 mm over their length. The two outer bearings shall articulate together as a pair to match the specimen surface, or the middle bearing shall articulate to match the specimen surface. All three bearings shall rest uniformly and evenly across the specimen surface. The fixture shall be designed to apply equal load to the two outer bearings.

**6.8 Fully-articulated Three-point Flexure**—Specimens that do not meet the parallelism requirements of 7.1 shall be tested in a fully-articulating fixture. Well-machined specimens may also be tested in a fully-articulating fixture. The two support (outer) bearings shall be free to roll outwards. The middle bearing shall not roll. Any two of the bearings shall be capable of articulating to match the specimen surface. All three bearings shall rest uniformly and evenly across the specimen surface. The fixture shall be designed to apply equal load to the two outer bearings.

**6.9** The fixture shall be stiffer than the specimen, so that most of the crosshead travel is imposed onto the specimen.

**6.10 Micrometer**—A micrometer with a resolution of 0.002 mm (or 0.0001 in.) or smaller should be used to measure the test specimen dimensions. The micrometer shall have flat anvil faces. The micrometer shall not have a ball tip or sharp tip since these might damage the test specimen if the specimen dimensions are measured prior to fracture. Alternative dimension measuring instruments may be used provided that they have a resolution of 0.002 mm (or 0.0001 in.) or finer and do no harm to the specimen.

## 7. Specimen

**7.1 Specimen Size**—Dimensions are given in Table 3 and shown in Fig. 4. Cross-sectional dimensional tolerances are

$\pm 0.13$  mm for B and C specimens, and  $\pm 0.05$  mm for A. The parallelism tolerances on the four longitudinal faces are 0.015 mm for A and B and 0.03 mm for C. The two end faces need not be precision machined.

**7.2 Specimen Preparation**—Depending upon the intended application of the flexural strength data, use one of the following four specimen preparation procedures:

**NOTE 8**—This test method does not specify a test specimen surface finish. Surface finish may be misleading since a ground, lapped, or even polished surface may conceal hidden, beneath the surface cracking damage from rough or intermediate grinding.

**7.2.1 As-Fabricated**—The flexural specimen shall simulate the surface condition of an application where no machining is to be used; for example, as-cast, sintered, or injection-molded parts. No additional machining specifications are relevant. An edge chamfer is not necessary in this instance. As-fired specimens are especially prone to twist or warpage and might not meet the parallelism requirements. In this instance, a fully articulating fixture (6.6 and Fig. 3) shall be used in testing.

**7.2.2 Application-Matched Machining**—The specimen shall have the same surface preparation as that given to a component. Unless the process is proprietary, the report shall be specific about the stages of material removal, wheel grits, wheel bonding, and the amount of material removed per pass.

**7.2.3 Customary Procedures**—In instances where a customary machining procedure has been developed that is completely satisfactory for a class of materials (that is, it induces no unwanted surface damage or residual stresses), this procedure shall be used.

**7.2.4 Standard Procedures**—In the instances where 7.2.1 through 7.2.3 are not appropriate, then 7.2.4 shall apply. This procedure shall serve as minimum requirements and a more stringent procedure may be necessary.

**7.2.4.1** All grinding shall be done with an ample supply of appropriate filtered coolant to keep workpiece and wheel constantly flooded and particles flushed. Grinding shall be in two or three stages, ranging from coarse to fine rates of material removal. All machining shall be in the surface grinding mode, and shall be parallel to the specimen long axis shown in Fig. 5. No Blanchard or rotary grinding shall be used. Machine the four long faces in accordance with the following paragraphs. The two end faces do not require special machining.

**7.2.4.2** Coarse grinding, if necessary, shall be with a diamond wheel no coarser than 150 grit. The stock removal rate (wheel depth of cut) shall not exceed 0.03 mm (0.001 in.) per pass to the last 0.060 mm (0.002 in.) per face. Remove approximately equal stock from opposite faces.

**7.2.4.3** Intermediate grinding, if utilized, should be done with a diamond wheel that is between 240 and 320 grit. The stock removal rate (wheel depth of cut) shall not exceed 0.006 mm (0.00025 in.) per pass to the last 0.020 mm (0.0008 in.) per face. Remove approximately equal stock from opposite faces.

**7.2.4.4** Finish grinding shall be with a diamond wheel that is between 400 and 600 grit. The stock removal rate (wheel depth of cut) shall not exceed 0.006 mm (0.00025 in.) per pass. Final grinding shall remove no less than 0.020 mm (0.0008 in.) per face. The combined intermediate and final grinding stages shall

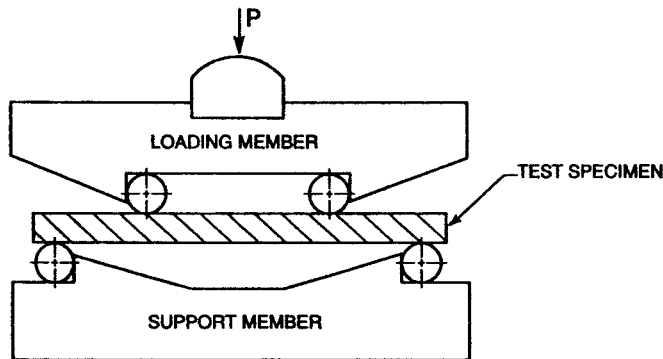
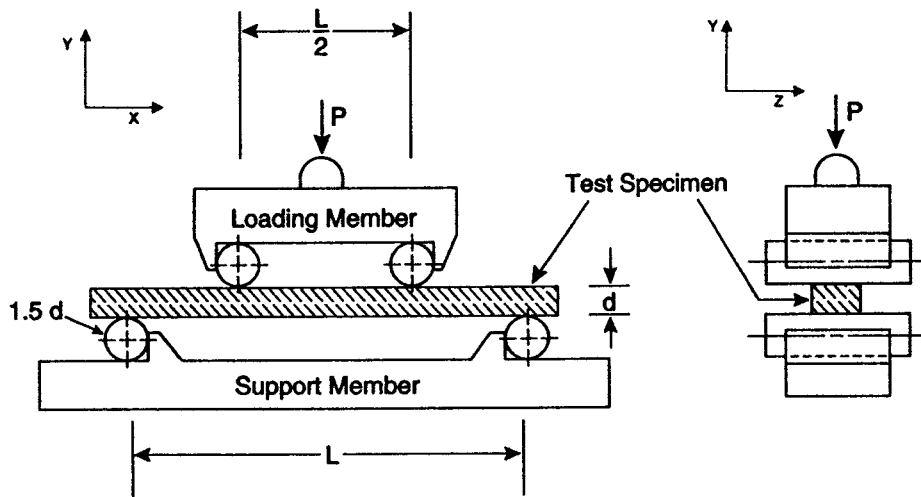

NOTE 1—Configuration:

- A:  $L = 20 \text{ mm}$
- B:  $L = 40 \text{ mm}$
- C:  $L = 80 \text{ mm}$

NOTE 2—Load is applied through a ball which permits the loading member to tilt as necessary to ensure uniform loading

**FIG. 2 Schematics of Two Semiarticulating Four-Point Fixtures Suitable for Flat and Parallel Specimens. Bearing Cylinders Are Held in Place by Low Stiffness Springs, Rubber Bands or Magnets**

remove no less than 0.060 mm (0.0025 in.) per face. Remove approximately equal stock from opposite faces.

7.2.4.5 Wheel speed should not be less than 25 m/sec (~1000 in./sec). Table speeds should not be greater than 0.25 m/sec (45 ft./min.).

7.2.4.6 The procedures in 7.2.4 address diamond grit size for coarse, intermediate, and finish grinding but leaves the choice of bond system (resin, vitrified), diamond type (natural or synthetic, coated or uncoated, friability, shape, etc.) and concentration (percent of diamond in the wheel) to the discretion of the user.

NOTE 9—The sound of the grinding wheel during the grinding process may be a useful indicator of whether the grinding wheel condition and material removal conditions are appropriate. It is beyond the scope of this standard to specify the auditory responses, however.

7.2.4.7 Materials with low fracture toughness and a greater susceptibility to grinding damage may require finer grinding wheels at very low removal rates.

7.2.4.8 The four long edges of each B-sized test specimen shall be uniformly chamfered at  $45^\circ$ , a distance of  $0.12 \pm 0.03 \text{ mm}$  as shown in Fig. 4. They can alternatively be rounded with a radius of  $0.15 \pm 0.05 \text{ mm}$ . Edge finishing must be comparable to that applied to the test specimen surfaces. In particular, the direction of machining shall be parallel to the test specimen long axis. If chamfers or rounds are larger than the tolerance allows, then corrections shall be made to the stress calculation in accordance with Annex A2. Smaller chamfer or rounded edge sizes are recommended for A-sized bars. Larger chamfers or rounded edges may be used with C-test specimens.

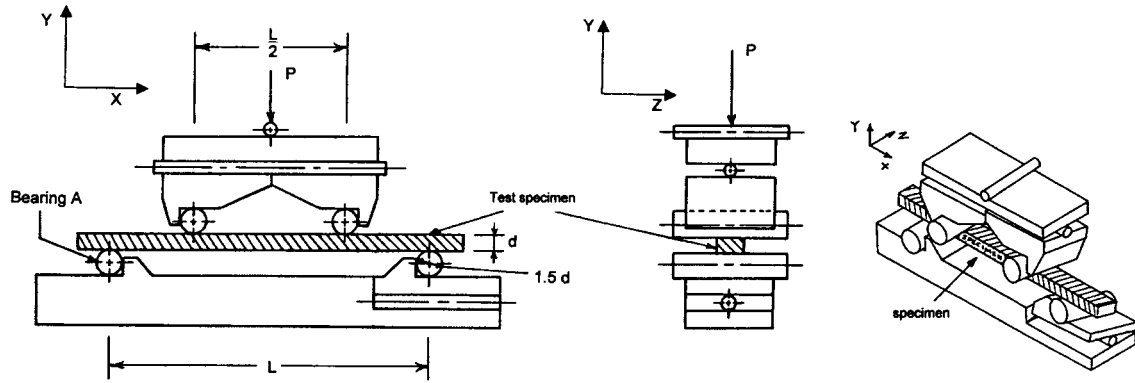

Note 1:  
Configuration

L, mm
A 20
B 40
C 80

Note 2—Bearing A is fixed so that it will not pivot about the x-axis. The other three bearings are free to pivot about the x axis.

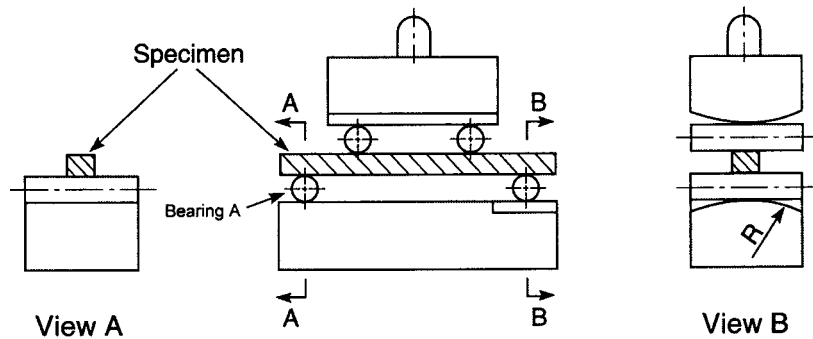

NOTE 1—Configuration:

- A: L = 20 mm
- B: L = 40 mm
- C: L = 80 mm

NOTE 2—Bearing A is fixed so that it will not pivot about the x axis. The other three bearings are free to pivot about the x axis.

FIG. 3 Schematics of Two Fully Articulating Four-Point Fixtures Suitable Either for Twisted or Uneven Specimens, or for Flat and Parallel Specimens. Bearing Cylinders Are Held in Place by Low Stiffness Springs, Rubber Bands, or Magnets

TABLE 3 Specimen Size

Configuration	Width (b), mm	Depth (d), mm	Length (L <sub>7</sub> ), min, mm
A	2.0	1.5	25
B	4.0	3.0	45
C	8.0	6.0	90

Consult Annex A2 for guidance and whether corrections for flexural strength are necessary. No chipping is allowed. Up to 50 X magnification may be used to verify this. Alternatively, if a test-specimen can be prepared with an edge that is free of machining damage, then a chamfer is not required.

7.2.4.9 Very deep skip marks or very deep single striations (which may occur due to a poor quality grinding wheel or due to a failure to true, dress, or balance a wheel) are not acceptable.

7.2.5 Handling Precautions and Scratch Inspection—Exercise care in storing and handling of specimens to avoid the

introduction of random and severe flaws, such as might occur if specimens were allowed to impact or scratch each other. If required by the user, inspect some or all of the surfaces as required for evidence of grinding chatter, scratches, or other extraneous damage. A 5X-10X hand loupe or a low power stereo binocular microscope may be used to aid the examination. Mark the scratched surface with a pencil or permanent marker if scratches or extraneous damage are detected. If such damage is detected, then the damaged surface should not be placed in tension, but instead on the compression mode of loading when the specimen is inserted into the test fixtures.

NOTE 10—Damage or scratches may be introduced by handling or mounting problems. Scratches are sometimes caused by loose abrasive grit.

7.3 Number of Specimens—A minimum of 10 specimens shall be required for the purpose of estimating the mean. A minimum of 30 shall be necessary if estimates regarding the form of the strength distribution are to be reported (for

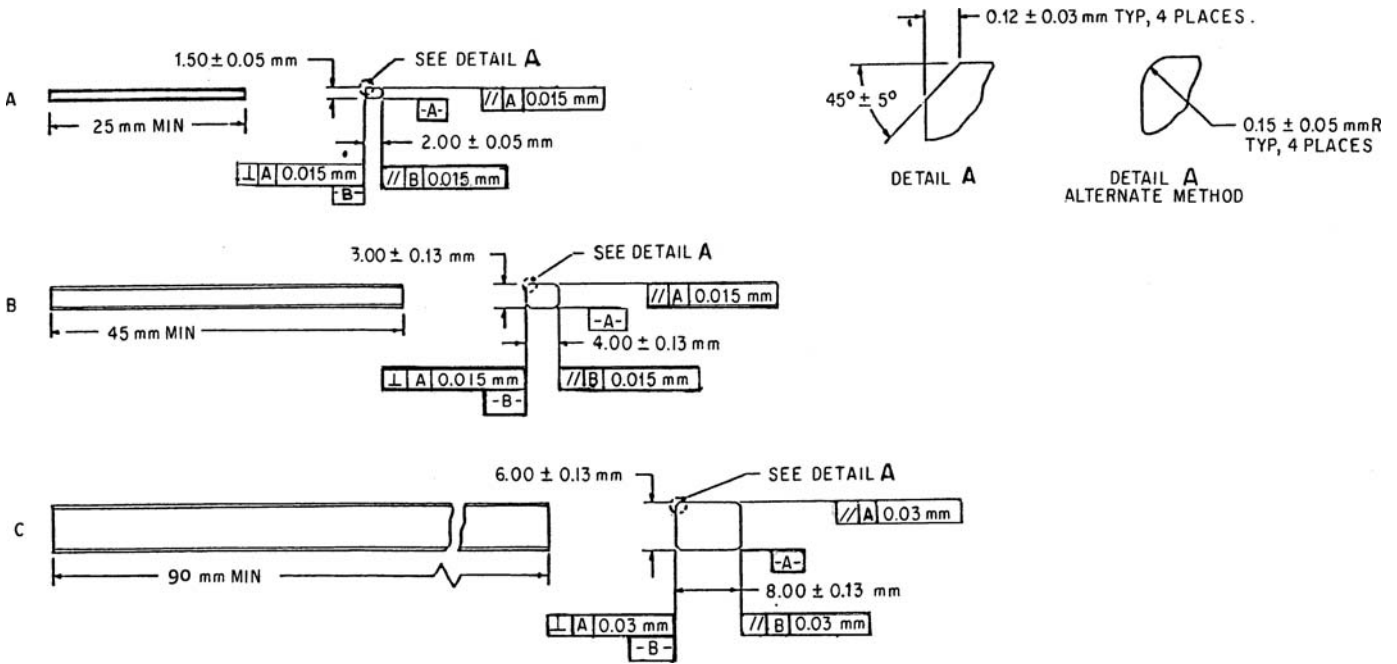

FIG. 4 The Standard Test Specimens

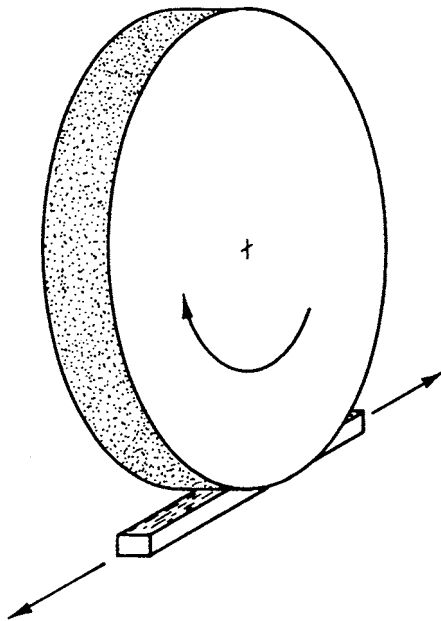

FIG. 5 Surface Grinding Parallel to the Specimen Longitudinal Axis

## 8. Procedure

8.1 Test specimens on their appropriate fixtures in specific testing configurations. Test specimens Size A on either the four-point A fixture or the three-point A fixture. Similarly, test B specimens on B fixtures, and C specimens on C fixtures. A fully articulating fixture is required if the specimen parallelism requirements cannot be met.

8.2 Carefully place each specimen into the test fixture to preclude possible damage and to ensure alignment of the specimen in the fixture. In particular, there should be an equal amount of overhang of the specimen beyond the outer bearings and the specimen should be directly centered below the axis of the applied load. If one of the wide specimen surfaces has been marked for the presence of a scratch or extraneous damage, then place the damaged surface so that it is loaded in compression. If a side surface is marked as damaged, then the specimen may be tested, but shall be inspected after the test to confirm that the scratch or damage did not cause fracture.

8.3 Slowly apply the load at right angles to the fixture. The maximum permissible stress in the specimen due to initial load shall not exceed 25 % of the mean strength. Inspect the points of contact between the bearings and the specimen to ensure even line loading and that no dirt or contamination is present. If uneven line loading of the specimen occurs, use fully articulating fixtures.

8.4 Mark the specimen to identify the points of load application and also so that the tensile and compression faces can be distinguished. Carefully drawn pencil marks will suffice. These marks assist in post fracture interpretation and analysis. If there is an excessive tendency for fractures to occur directly (within 0.5 mm) underneath a four-point flexure inner bearing, then check the fixture alignment and articulation. Specimen shape irregularities may also contribute to excessive

example, a Weibull modulus). The number of specimens required by this test method has been established with the intent of determining not only reasonable confidence limits on strength distribution parameters, but also to help discern multiple-flaw population distributions. More than 30 specimens are recommended if multiple-flaw populations are present.

NOTE 11—Practice C1239 may be consulted for additional guidance particularly if confidence intervals for estimates of Weibull parameters are of concern.

load point breakages. [Appendix X1](#) may be consulted for assistance with interpretation.

**NOTE 12**—Secondary fractures often occur at the four-point inner bearings and are harmless.

**NOTE 13**—Occasional breaks outside the inner gage section in four-point fracture are not unusual, particularly for materials with low Weibull moduli (large scatter in strengths). These fractures can often be attributed to atypical, large natural flaws in the material.

8.5 Put cotton, crumbled tissues, or other appropriate material around specimen to prevent pieces from flying out of the fixtures upon fracture. This step may help ensure operator's safety and preserve primary fracture pieces for subsequent fractographic analysis.

8.6 *Loading Rates*—The crosshead rates are chosen so that the strain rate upon the specimen shall be of the order of  $1.0 \times 10^{-4} \text{ s}^{-1}$ .

8.6.1 The strain rate for either the three- or four-point- $\frac{1}{4}$  point mode of loading is as follows:

$$\varepsilon = 6 \text{ ds/L}^2$$

where:

- $\varepsilon$  = strain rate,
- $d$  = specimen thickness,
- $s$  = crosshead speed, and
- $L$  = outer (support) span.

8.6.2 Crosshead speeds for the different testing configurations are given in [Table 4](#).

8.6.3 Times to failure for typical ceramics will range from 3 to 30 s. It is assumed that the fixtures are relatively rigid and that most of the testing-machine crosshead travel is imposed as strain on the test specimen.

8.6.4 If it is suspected that slow crack growth is active (which may interfere with measurement of the flexural strength) to a degree that it might cause a rate dependency of the measured flexural strength, then faster testing rates should be used.

**NOTE 14**—The sensitivity of flexural strength to stressing rate may be assessed by testing at two or more rates. See Test Method [C1368](#).

8.7 *Break Force*—Measure the break force with an accuracy of  $\pm 0.5 \%$ .

8.8 *Specimen Dimension*—Determine the thickness and width of each specimen to within 0.0025 mm (0.0001 in.). In order to avoid damage in the critical area, it is recommended that measurement be made after the specimen has broken at a point near the fracture origin. It is highly recommended to retain and preserve all primary fracture fragments for fractographic analysis.

8.9 Determine the relative humidity in accordance with Test Method [E337](#).

8.10 The occasional use of a strain-gaged specimen is recommended to verify that there is negligible error in stress, in accordance with [11.2](#).

8.11 Reject all specimens that fracture from scratches or other extraneous damage.

8.12 Specimens which break outside of the inner gage section are valid in this test method, provided that their occurrence is infrequent. Frequent breakages outside their inner gage section ( $\sim 10\%$  or more of the specimens) or frequent primary breakages directly under (within 0.5 mm) an inner bearing are grounds for rejection of a test set. The specimens and fixtures should be checked for alignment and articulation.

**NOTE 15**—Breaks outside the inner gage section sometimes occur due to an abnormally large flaw and there is nothing wrong with such a test outcome. The frequency of fractures outside the inner gage section depends upon the Weibull modulus (more likely with low moduli), whether there are multiple flaw populations, and whether there are stray flaws. Breakages directly under an inner load pin sometimes occur for similar reasons. In addition, many apparent fractures under a load pin are in fact legitimate fractures from an origin close to, but not directly at the load pin. Secondary fractures in specimens that have a lot of stored elastic energy (that is, strong specimens) often occur right under a load pin due to elastic wave reverberations in the specimen. See [Appendix X1](#) for guidance.

8.13 Fractographic analysis of broken specimens is highly recommended to characterize the types, locations, and sizes of fracture origins as well as possible stable crack extension due to slow crack growth. Follow the guidelines in Practice [C1322](#). Only some specimen pieces need to be saved. Tiny fragments or shards are often inconsequential since they do not contain the fracture origin. With some experience, it is usually not difficult to determine which pieces are important and should be retained. It is recommended that the test specimens be retrieved with tweezers after fracture, or the operator may wear gloves in order to avoid contamination of the fracture surfaces for possible fractographic analysis. See [Fig. X1.1](#) for guidance. If there is any doubt, then all pieces should be preserved.

8.14 Inspect the chamfers or edge round if such exist. If they are larger than the sizes allowed in [7.2.4.4](#) and [Fig. 4](#), then the flexural strength shall be corrected as specified in [Annex A2](#).

## 9. Calculation

9.1 The standard formula for the strength of a beam in four-point- $\frac{1}{4}$  point flexure is as follows:

$$S = \frac{3 PL}{4 bd^2} \quad (1)$$

where:

- $P$  = break force,
- $L$  = outer (support) span,
- $b$  = specimen width, and
- $d$  = specimen thickness.

9.2 The standard formula for the strength of a beam in three-point flexure is as follows:

$$S = \frac{3 PL}{2 bd^2} \quad (2)$$

**TABLE 4 Crosshead Speeds for Displacement-Controlled Testing Machine**

Configuration	Crosshead Speeds, mm/min
A	0.2
B	0.5
C	1.0



9.3 Eq 1 and Eq 2 shall be used for the reporting of results and are the common equations used for the flexure strength of a specimen.

NOTE 16—It should be recognized however, that Eq 1 and Eq 2 do not necessarily give the stress that was acting directly upon the origin that caused failure (In some instances, for example, for fracture mirror or fracture toughness calculations, the fracture stress must be corrected for subsurface origins and breaks outside the gage length.). For conventional Weibull analyses, use the maximum stress in the specimen at failure from Equations 1 and 2.

NOTE 17—The conversion between pounds per square inch (psi) and megapascals (MPa) is included for convenience (145.04 psi = 1 MPa; therefore, 100 000 psi = 100 ksi = 689.5 MPa.)

9.4 If the specimens edges are chamfered or rounded, and if the sizes of the chamfers or rounds exceeds the limits in 7.2.4.8 and Fig. 4, then the strength of the beam shall be corrected in accordance with Annex A.

10. Report

10.1 Test reports shall include the following:

10.1.1 Test configuration and specimen size used.

10.1.2 The number of specimens (n) used.

10.1.3 All relevant material data including vintage data or billet identification data if available. (Did all specimens come from one billet?) As a minimum, the date the material was manufactured shall be reported.

10.1.4 Exact method of specimen preparation, including all stages of machining if available.

10.1.5 Heat treatments or exposures, if any.

10.1.6 Test environment including humidity (Test Method E337) and temperature.

10.1.7 Strain rate or crosshead rate.

10.1.8 Report the strength of every specimen in megapascals (pounds per square inch) to three significant figures.

10.1.9 Mean ( $\bar{S}$ ) and standard deviation (SD) where:

$$\bar{S} = \frac{\sum_1^n S}{n} \tag{3}$$

$$SD = \sqrt{\frac{\sum_1^n (S - \bar{S})^2}{(n - 1)}}$$

10.1.10 Report of any deviations and alterations from the procedures described in this test method.

10.1.11 The following notation may be used to report the mean strengths:

$S_{(N,L)}$  to denote strengths measured in (N= 4 or 3) -point flexure, and (L = 20, 40, or 80 mm) fixture outer span size

EXAMPLES

$S_{(4,40)} = 537$  MPa denotes the mean flexural strength was 537 MPa when measured in four-point flexure with 40 mm span fixtures.

$S_{(3,20)} = 610$  MPa denotes the mean flexural strength was 610 MPa when measured in three-point flexure with 20 mm span fixtures.

The relative humidity or test environment may also be reported as follows:

$S_{(N,L)} = XXX$  [RH% or environment] to denote strengths measured in an atmosphere with RH% relative humidity or other environment

EXAMPLES

$S_{(4,40)} = 600$  MPa [45 %] denotes the mean flexural strength was 600 MPa when measured in four-point flexure with 40 mm span fixtures in lab ambient conditions with 45 % relative humidity.

$S_{(3,40)} = 705$  MPa [dry N<sub>2</sub>] denotes the mean flexural strength was 705 MPa when measured in three-point flexure with 40 mm span fixtures in a dry nitrogen gas environment.

$S_{(3,20)} = 705$  MPa [vacuum] denotes the mean flexural strength was 705 MPa when measured in three-point flexure with 20 mm span fixtures in a vacuum environment.

11. Precision and Bias

11.1 The flexure strength of a ceramic is not a deterministic quantity, but will vary from one specimen to another. There will be an inherent statistical scatter in the results for finite sample sizes (for example, 30 specimens). Weibull statistics can model this variability as discussed in Practice C1322 and Refs. (6–10). This test method has been devised so that the precision is very high and the bias very low compared to the inherent variability of strength of the material.

11.2 Experimental Errors:

11.2.1 The experimental errors in the flexure test have been thoroughly analyzed and documented in Ref (1). The specifications and tolerances in this test method have been chosen such that the individual errors are typically less than 0.5 % each and the total error is probably less than 3 % for four-point configurations B and C. (A conservative upper limit is of the order of 5 %.) This is the maximum possible error in stress for an individual specimen.

11.2.2 The error due to cross-section reduction associated with chamfering the edges can be of the order of 1 % for configuration B and less for configuration C in either three or four-point loadings, as discussed in Ref (1). The chamfer sizes in this test method have been reduced relative to those allowed in MIL-STD-1942 (MR). Chamfers larger than specified in this test method shall require a correction to stress calculations as discussed in Ref (1).

11.2.3 Configuration A is somewhat more prone to error which is probably greater than 5 % in four-point loading. Chamfer error due to reduction of cross-section areas is 4.1 %. For this reason, this configuration is not recommended for design purposes, but only for characterization and materials development.

11.3 An intralaboratory comparison of strength values of a high purity (99.9 %) sintered alumina was held (7)<sup>5</sup>. Three different individuals with three different universal testing machines on three different days compared the strength of lots of 30 specimens from a common batch of material. Three different fixtures, but of a common design, were used. The mean strengths varied by a maximum of 2.4 % and the Weibull moduli by a maximum of 27 % (average of 11.4). Both variations are well within the inherent scatter predicted for sample sizes of 30 as shown in Refs (1), (7), and (9).

<sup>5</sup> Research report C28-1001 has the results for the interlaboratory study as well as several of the background references for C1161.

11.4 An interlaboratory comparison of strength of the same alumina as cited in 11.3 was made between two laboratories<sup>5</sup>. A 1.3 % difference in the mean and an 18 % difference in Weibull modulus was observed, both of which are well within the inherent variability of the material.

11.5 An interlaboratory comparison of strength of a different alumina and of a silicon nitride was made between seven international laboratories<sup>5</sup>. Reference (7) is a comprehensive report on this study which tested over 2000 specimens. Experimental results for strength variability on B specimens, in

both three- and four-point testing, were generally consistent with analytical predictions of Ref (9). For a material with a Weibull modulus of 10, estimates of the mean (or characteristic strength) for samples of 30 specimens will have a coefficient of variance of 2.2 %. The coefficient of variance for estimates of the Weibull modulus is 18 %.

## 12. Keywords

12.1 advanced ceramics; flexural strength; four-point flexure; three-point flexure

ANNEXES

A1. SEMI- AND FULLY-ARTICULATING FOUR-POINT FIXTURES

A1.1 The schematic figures in Fig. A1.1 illustrate semi-articulated and fully-articulated degrees of freedom in the text fixtures. Fully-articulated fixtures shall be used for specimens

that are not parallel or flat. Fully-articulated fixtures may be used for well-machined specimens. Semi-articulating fixtures shall only be used with flat and parallel specimens.

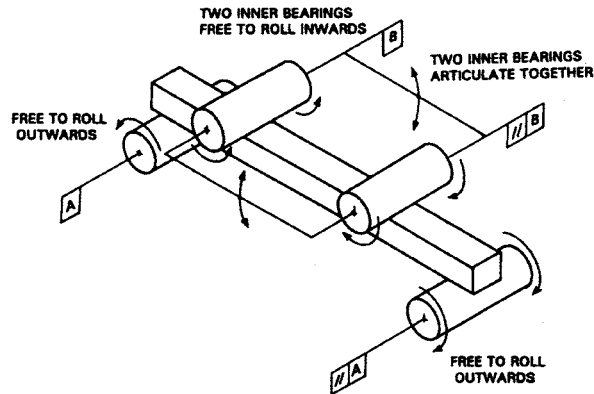

- (a) **SEMI-ARTICULATING.** The two inner bearings are parallel to each other and the bearings are free to roll inwards. The two outer bearings are parallel to each other, and the bearings are free to roll outwards. The two inner bearings can articulate together as a pair to match the specimen top surface. (Alternatively, the two bottom bearings can articulate to match the bottom surface.)

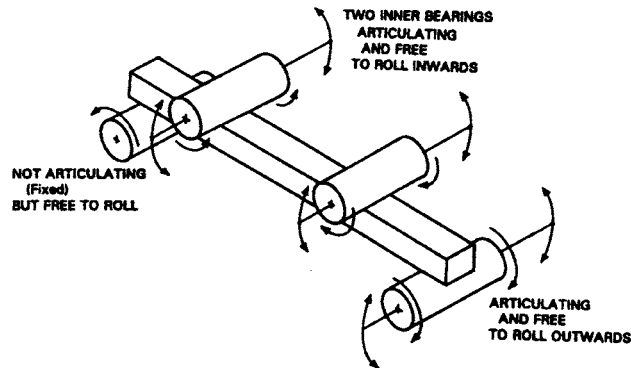

- (b) **FULLY-ARTICULATING.** The two inner bearings are free to roll inwards, and they can independently articulate to match the specimen top surface. The two outer bearings are free to roll, and one bearing can articulate to match the specimen bottom surface.

FIG. A1.1 Four-Point Flexure Fixture

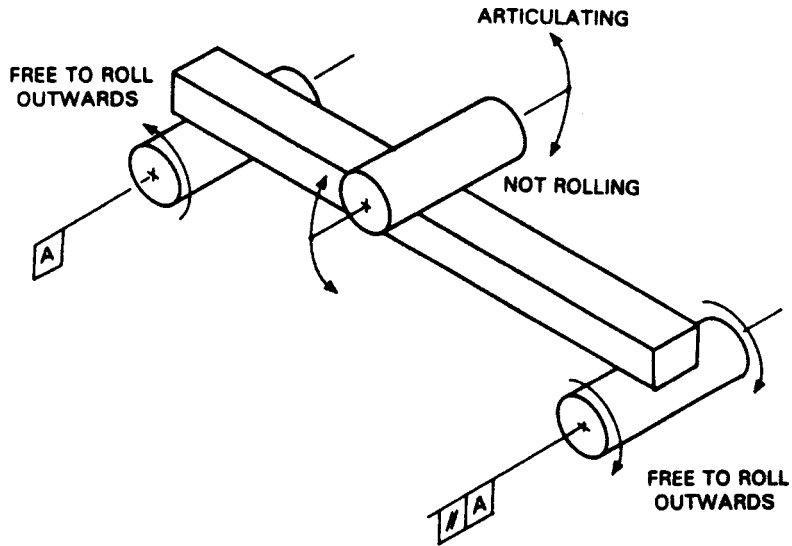

- (a) **SEMI-ARTICULATING.** The two support bearings are parallel to each other and they are free to roll outward. The middle bearing does not roll, but it can articulate to match the specimen top surface.

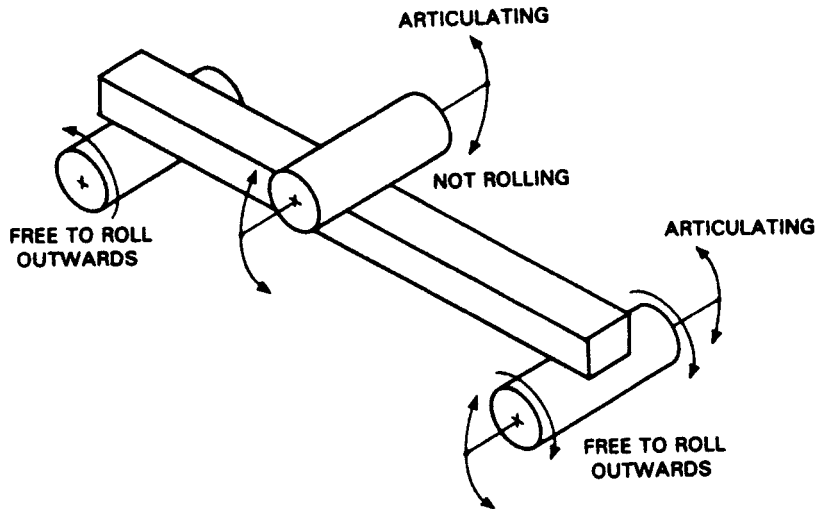

- (b) **FULLY-ARTICULATING** The two support bearings are free to roll outward. One support bearing can articulate to match the specimen surface. The middle bearing does not roll, but it can articulate to match the specimen top surface.

FIG. A1.2 Three-Point Flexure Fixture

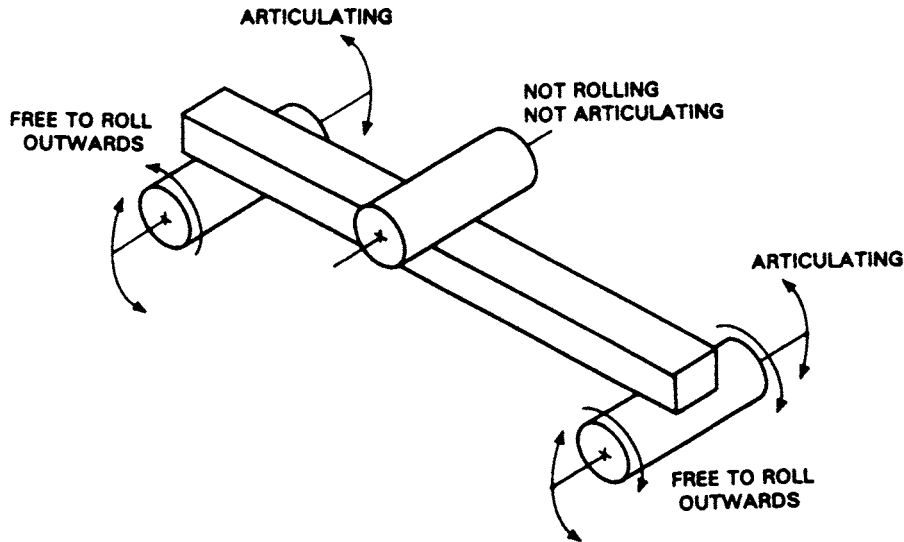

- (c) **FULLY-ARTICULATING (Alternative design)** The two support bearings are free to roll outward. Both support bearings can articulate to match the specimen surface. The middle bearing does not roll and does not articulate.

FIG. A1.2 Three-Point Flexure Fixture (continued)

## A2. CHAMFER CORRECTION FACTORS

A2.1 Flexural strengths shall be corrected for oversized corner chamfers or edge rounds ( $c_{max} > 0.15$  mm for chamfers or  $R_{max} > 0.20$  mm for edge rounds). Chamfers or rounded edges cause an underestimate of the true maximum flexural strength, if not considered in the calculations.

A2.2 The maximum stress in a flexure test specimen is customarily calculated from simple beam theory with the assumption that the test specimen has a rectangular cross section. The test specimen chamfers reduce the second moment of inertia,  $I$ , of the test specimen cross section about the neutral axis. For a perfect rectangular cross section,  $I = (bh^3)/12$ . For a rectangular cross section with four chamfered edges of size  $c$ , the adjusted moment of inertia from reference 1 is:

$$I = \frac{bh^3}{12} - \frac{c^2}{9} (c^2 + \frac{1}{2} (3h - 2c)^2) \quad (A2.1)$$

where the second term on the right hand side shows the reduction due to the chamfers.

A2.3 The chamfer size,  $c$ , may be measured with a traveling microscope, photo analysis, or a microscope with a traversing

stage. All four chamfers should be measured and an average value used for the correction. The most accurate results may be obtained by measuring each test specimen, but for many applications, an approximate average chamfer size based on a sample of 5 test specimens may be adequate.

A2.4 The correct flexural strength  $S$  may be obtained by multiplying the apparent flexural strength,  $S'$ , (calculated on the assumption the cross section is a simple rectangle) by a correction factor,  $F$ .

$$S = FS' \quad (A2.2)$$

A2.5 Correction factors,  $F$ , for chamfers or rounded edges for standard A, B, C sized specimens are listed below. In accordance with 9.4 and A2.4, the flexural strength shall be corrected if the chamfers are larger than the sizes highlighted by the lines in Table A2.1 and Table A2.2. See Tables A2.1 and A2.2.

TABLE A2.1 Correction factor, F, for chamfers on A, B, and C specimens. The lines in the table correspond to an approximate flexural strength error of 1 percent.

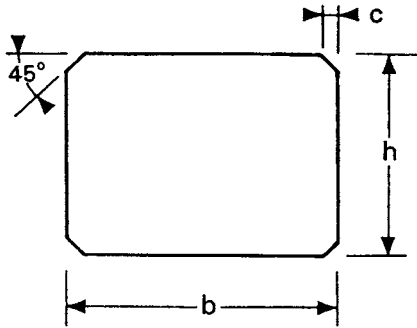

Chamfer Geometry

c (mm)	Correction factor, F		
	Configuration "A" b = 2 mm, d= 1.5 mm	Configuration "B" b = 4 mm, d= 3 mm	Configuration "C" b = 8 mm, d= 6 mm
0.080	1.0121	1.0031	1.0008
0.090	1.0152	1.0039	1.0010
0.100	1.0186	1.0048	1.0012
0.110	1.0224	1.0058	1.0015
0.120	1.0265	1.0069	1.0018
0.130	1.0310	1.0080	1.0021
0.140	1.0358	1.0093	1.0024
0.150	1.0409	1.0106	1.0027
0.160	1.0464	1.0121	1.0031
0.170	1.0521	1.0136	1.0035
0.180	1.0583	1.0152	1.0039
0.190	1.0647	1.0169	1.0043
0.200	1.0715	1.0186	1.0048
0.210	1.0786	1.0205	1.0053
0.220	1.0861	1.0224	1.0058
0.230	1.0939	1.0244	1.0063
0.240	1.1020	1.0265	1.0069
0.250	1.1105	1.0287	1.0074
0.260	1.1194	1.0310	1.0080
0.270	1.1286	1.0333	1.0087
0.280	1.1382	1.0358	1.0093
0.290	1.1481	1.0383	1.0099
0.300	1.1585	1.0409	1.0106

TABLE A2.2 Correction factor, F, for rounded edges on A, B, and C specimens. The lines in the table correspond to an approximate flexural strength error of 1 percent.

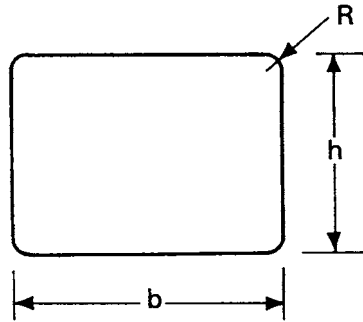

Rounded Edge Geometry			
R (mm)	Correction factor, F Configuration "A" b = 2 mm, d = 1.5 mm	Correction factor, F Configuration "B" b = 4 mm, d = 3 mm	Correction factor, F Configuration "C" b = 8 mm, d = 6 mm
0.080	1.0053	1.0013	1.0003
0.090	1.0066	1.0017	1.0004
0.100	1.0082	1.0021	1.0005
0.110	1.0098	1.0025	1.0006
0.120	1.0116	1.0030	1.0008
0.130	1.0136	1.0035	1.0009
0.140	1.0157	1.0041	1.0010
0.150	1.0180	1.0046	1.0012
0.160	1.0204	1.0053	1.0013
0.170	1.0229	1.0059	1.0015
0.180	1.0256	1.0066	1.0017
0.190	1.0284	1.0074	1.0019
0.200	1.0314	1.0082	1.0021
0.210	1.0345	1.0090	1.0023
0.220	1.0378	1.0098	1.0025
0.230	1.0412	1.0107	1.0027
0.240	1.0447	1.0116	1.0030
0.250	1.0484	1.0126	1.0032
0.260	1.0522	1.0136	1.0035
0.270	1.0562	1.0146	1.0038
0.280	1.0603	1.0157	1.0041
0.290	1.0646	1.0168	1.0043
0.300	1.0690	1.0180	1.0046

APPENDIXES

X1. TYPICAL FRACTURE PATTERNS IN CERAMIC FLEXURE SPECIMENS

X1.1 Fig. X1.1 illustrates fracture patterns that are commonly observed in ceramic specimens. Low-strength ceramics, which have a low energy level at fracture, typically break into only two pieces. Medium- to high-strength ceramics break into

more pieces. Fractographic analysis can assist in determining the primary fracture origin. See Practice C1322 for further guidance.

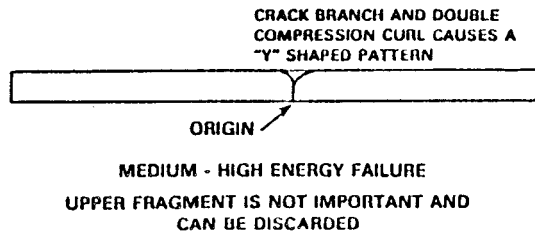
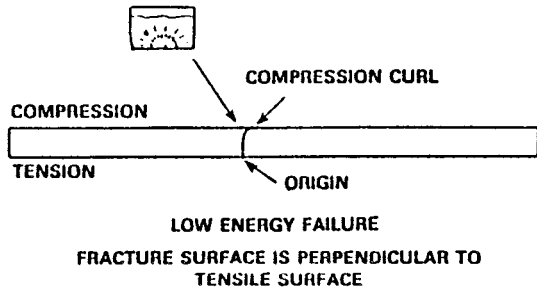
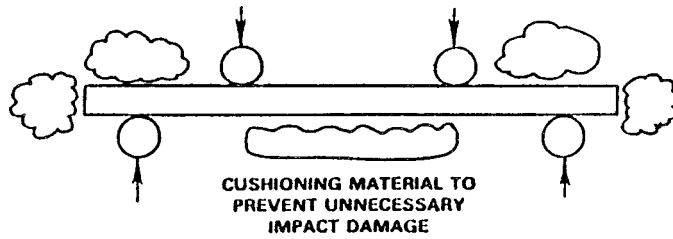

A SECONDARY FRACTURE CAUSED BY THE ELASTIC RELEASE WAVE - REFLECTION OFF OF THE END FACES. NOTE THIS OFTEN OCCURS AT LOAD PINS. NOTE THE MIRROR IS ON WHAT ORIGINALLY WAS THE COMPRESSION SIDE.

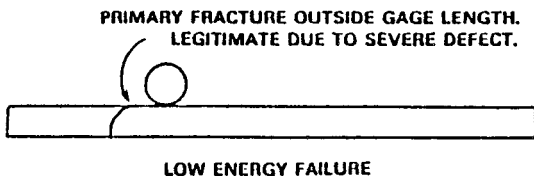
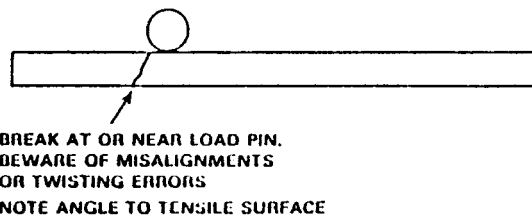
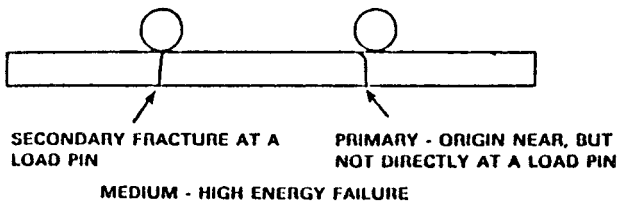
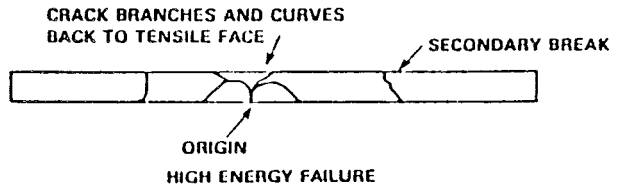
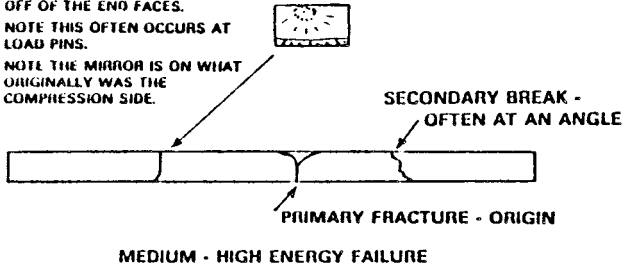
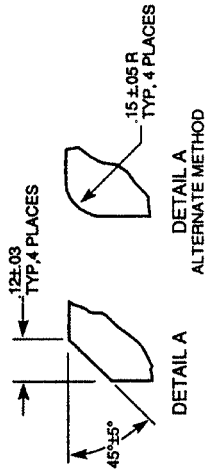
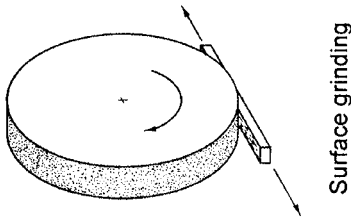

FIG. X1.1 Typical Fracture and Crack Patterns of Flexure Specimens



## X2. STANDARD “B” FLEXURAL STRENGTH SPECIMEN

X2.1 Fig. X2.1 is an engineering drawing of a standard “B” sized specimen that is in accordance with the preparation requirements of 7.2.4.



ALL DIMENSIONS ARE IN MILLIMETERS  
UNLESS OTHERWISE NOTED  
SCALE: None

# ASTM C 1161-2002

Standard "B" Flexural Strength Specimen  
(and MIL STD 1942 and ISO 14704 with exceptions noted below)  
(See paragraphs 7.1 and 7.2.4.4 and Figure 4 of C 1161 for dimensions and tolerances for "A" and "C" specimens.)

ISO 14704 specifies a 320 – 800 grit wheel for final finishing.  
ISO 14704 has cross section tolerances of 0.20 mm, not 0.13 mm.  
MIL STD 1942 had a cross section tolerance of 0.03 mm, not 0.13 mm.  
MIL STD 1942 specified a 200 – 500 grit wheel for final finishing.

Sym	date	Description

Original Date of Drawing: July 18, 2001  
U.S. Dept of Commerce, NIST for ASTM C 1161  
Submitted by: G. Quinn

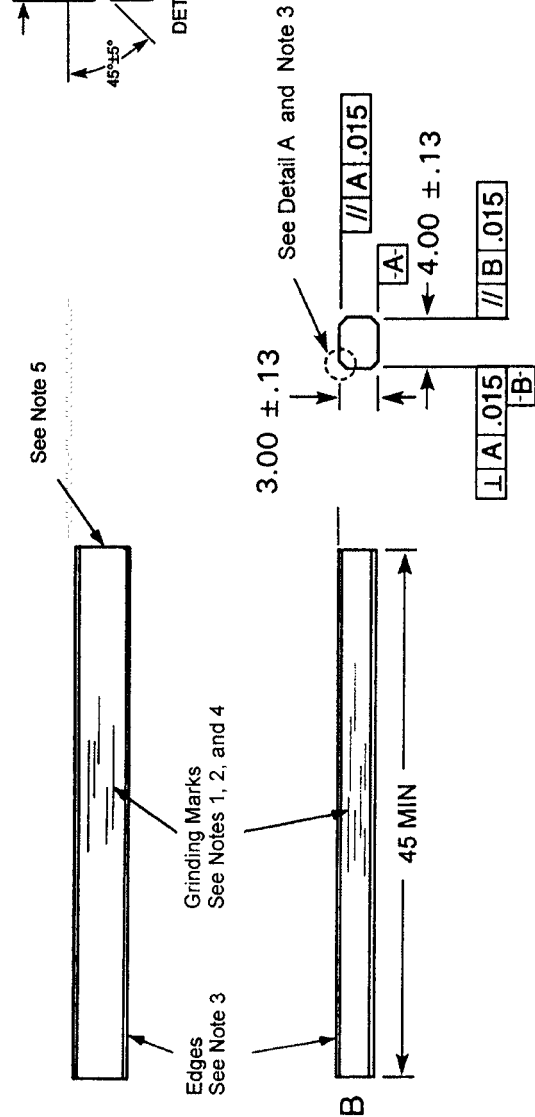

### NOTES

- The four flat surfaces shall be ground longitudinally unless otherwise specified. Blanchard or rotary grinding is not permitted during any phase of specimen preparation. Specimens shall be ground in progressively finer stages in order to control the depth of machining damage and microcracking. Grinding shall be in two or three stages. All grinding shall be done with an ample supply of appropriate filtered coolant to keep work piece and wheel constantly flooded and particles flushed. Coarse grinding, if necessary, shall be with a diamond wheel no coarser than 150 grit. The stock removal rate (wheel depth of cut) shall not exceed 0.03 mm (0.001 in) per pass to the last 0.06 mm (0.002 in) per face. Remove approximately equal stock from opposite faces. Intermediate grinding, if utilized, should be done with a diamond wheel that is between 240-320 grit. The stock removal rate (wheel depth of cut) shall not exceed 0.006 mm (0.00025 in) per pass to the last 0.020 mm (0.0008 in.) per face. Remove approximately equal stock from opposite faces. Finish grinding shall be with a diamond wheel that is between 400 and 600 grit. The stock removal rate (wheel depth of cut) shall not exceed 0.006 mm (0.00025 in) per pass. Final grinding shall remove no less than 0.020 mm (0.0008 in.) per face. The combined intermediate and final grinding stages shall remove no less than 0.060 mm (0.0025 in) per face. Remove approximately equal stock from opposite faces. Wheel speeds should not be less than 25 m/sec (~1000 inch/sec). Table speeds should not be greater than 0.25 m/sec (45 feet/min). Very deep skip marks or very deep single striations, which may occur due to a poor quality grinding wheel or due to a failure to true, dress, or balance a wheel, are not acceptable.
- A surface finish tolerance is not required in ASTM C 1161, MIL STD 1942, nor ISO 14704. Nevertheless, with careful grinding control, the finish for a fully dense ceramic should be 0.2 rms micrometers (8 rms micro inches) or finer as measured length wise, or 0.4 micrometers (15 rms micro inches) or finer as measured transverse to the specimen long axis. If the ceramic is porous, coarser finishes may be expected.
- Edge finishing must be comparable to that applied to the specimen surfaces. In particular, the direction of machining shall be parallel to the specimen long axis. All four edges shall be chamfered or rounded. No chipping on the chamfers is allowed. 50X magnification may be used to verify the edge condition. Alternatively, if a specimen can be prepared with an edge that is free of machining damage or chips, then chamfers or rounding are not required.
- Optional: Inspect the surfaces for evidence of grinding chatter or scratches. Mark the scratched surface if scratches are detected.
- The end faces do not require special machining.
- Bars shall be individually wrapped or packaged when delivered.

FIG. X2.1

### X3. DIFFERENCES BETWEEN C1161 AND MIL STD 1942

X3.1 Test method C1161 has officially replaced standards MIL STD 1942(MR) and MIL STD 1942A that were issued by the United States Army Materials Research Laboratory, Watertown, Massachusetts. The former was a U.S. Army standard adopted in November 1983 and it was replaced by the tri service MIL STD 1942A on November 8, 1990. MIL STD 1942A had many revisions to harmonize it with the ASTM C1161-90. MIL STD 1942A was officially cancelled and replaced by C1161 on 29 May 1998

X3.2 MIL STD 1942(MR), MIL STD 1942A, and C1161 have some differences that are listed in the following paragraphs.

X3.3 The chamfers in MIL STD 1942(MR) were 0.15 mm for a 45 degree chamfer and 0.20 mm for a rounded edge. The sizes were reduced to 0.12 mm and 0.15 mm in MIL STD 1942A and C1161.

X3.4 The parallelism tolerance for test fixture bearing cylinders was reduced from 0.030 mm in MIL STD 1942(MR) to 0.015 mm in MIL STD 1942A and C1161.

X3.5 MIL STD 1942(MR) allowed 200 to 500 grit wheels for final finish grinding. MIL STD 1942A and the 1990, 1994 and 1996 versions of C1161 specified 320-500 grit wheels for finish grinding.

X3.6 C1161 and MIL STD 1942A have a requirement (not found in MIL STD 1942(MR)) that the specimen be centered in the fixtures to within 0.10 mm in the z direction.

X3.7 The ¼ inch × ⅛ inch × 2 inch specimen on a 1.5 inch × 0.75 inch test fixture, configuration D, specified in an Appendix in the 1990, 1994 and 1996 versions of C1161 was never in the MIL STD's.

X3.8 The MIL STD's had tighter tolerances than C1161 on the specimen cross section dimensions (0.03 mm versus 0.13 mm).

X3.9 The MIL STD's did not include the "Customary Procedures" specimen preparation option.

X3.10 The MIL STD's had no specific limit on the amount of preloading allowed during the fracture test whereas C1161 has a limit of 25 % of the mean strength.

### REFERENCES

- (1) Baratta, F. I., Quinn, G. D., and Matthews, W. T., "Errors Associated With Flexure Testing of Brittle Materials," U.S. Army MTL TR 87-35, July 1987.
- (2) Quinn, G. D., Baratta, F. I., and Conway, J. A., "Commentary on U.S. Army Standard Test Method for Flexural Strength of High Performance Ceramics at Ambient Temperature," U.S. Army AM-MRC 85-21, August 1985.
- (3) Hoagland, R., Marshall, C., and Duckworth, W., "Reduction of Errors in Ceramic Bend Tests," *Journal of the American Ceramic Society*, Vol 59, No. 5-6, May-June, 1976, pp. 189-192.
- (4) Quinn, G.D. and Morrell, "Design Data for Engineering Ceramics: A Review of the Flexure Test," *Journal of the American Ceramic Society*, Vol 74 [9], 1991, pp. 2037-66.
- (5) Quinn, G. D., "Properties Testing and Materials Evaluation," *Ceramic Engineering and Science Proceedings*, Vol 5, May-June 1984, pp. 298-311.
- (6) Quinn, G. D., "Fractographic Analysis and the Army Flexure Test Method," *Fractography of Glass and Ceramics*, Vol 22 of *Advances in Ceramics*, American Ceramic Society, 1988, pp. 314-334.
- (7) Quinn, G. D., "Flexure Strength of Advanced Structural Ceramics: A Round Robin," *Journal of the American Ceramic Society*, Vol 73 [8], ( 1990), pp. 2374-84.
- (8) Davies, D. G. S., "The Statistical Approach to Engineering Design in Ceramics," *Proceedings of the British Ceramic Society*, Vol 22, 1979, pp. 429-452.
- (9) Ritter, J. Jr., Bandyopadhyay, N., and Jakus, K., "Statistical Reproducibility of the Dynamic and Static Fatigue Experiments," *Ceramic Bulletin*, Vol 60, No. 8, 1981, pp. 798-806.
- (10) Weibull, W., "Statistical Distribution Function of Wide Applicability," *Journal of Applied Mechanics*, Vol 18, 1951, p. 293.
- (11) Tennery, V., "International Energy Agency Annex II," *Ceramic Technology Newsletter*, Number 23, April-June 1989.

*ASTM International takes no position respecting the validity of any patent rights asserted in connection with any item mentioned in this standard. Users of this standard are expressly advised that determination of the validity of any such patent rights, and the risk of infringement of such rights, are entirely their own responsibility.*

*This standard is subject to revision at any time by the responsible technical committee and must be reviewed every five years and if not revised, either reapproved or withdrawn. Your comments are invited either for revision of this standard or for additional standards and should be addressed to ASTM International Headquarters. Your comments will receive careful consideration at a meeting of the responsible technical committee, which you may attend. If you feel that your comments have not received a fair hearing you should make your views known to the ASTM Committee on Standards, at the address shown below.*

*This standard is copyrighted by ASTM International, 100 Barr Harbor Drive, PO Box C700, West Conshohocken, PA 19428-2959, United States. Individual reprints (single or multiple copies) of this standard may be obtained by contacting ASTM at the above address or at 610-832-9585 (phone), 610-832-9555 (fax), or service@astm.org (e-mail); or through the ASTM website (www.astm.org). Permission rights to photocopy the standard may also be secured from the ASTM website (www.astm.org/COPYRIGHT/).*