



Standard Test Method for Linear-Elastic Plane-Strain Fracture Toughness K_{Ic} of Metallic Materials¹

This standard is issued under the fixed designation E399; the number immediately following the designation indicates the year of original adoption or, in the case of revision, the year of last revision. A number in parentheses indicates the year of last reapproval. A superscript epsilon (ϵ) indicates an editorial change since the last revision or reapproval.

This standard has been approved for use by agencies of the Department of Defense.

^{ε1} NOTE—3.1.3 was editorially revised in May 2013.

^{ε2} NOTE—Note 2 of Fig. A2.2 was editorially revised in October 2013.

1. Scope

1.1 This test method covers the determination of fracture toughness (K_{Ic}) of metallic materials under predominantly linear-elastic, plane-strain conditions using fatigue precracked specimens having a thickness of 1.6 mm (0.063 in.) or greater² subjected to slowly, or in special (elective) cases rapidly, increasing crack-displacement force. Details of test apparatus, specimen configuration, and experimental procedure are given in the Annexes.

NOTE 1—Plane-strain fracture toughness tests of thinner materials that are sufficiently brittle (see 7.1) can be made using other types of specimens (1).³ There is no standard test method for such thin materials.

1.2 This test method is divided into two parts. The first part gives general recommendations and requirements for K_{Ic} testing. The second part consists of Annexes that give specific information on displacement gage and loading fixture design, special requirements for individual specimen configurations, and detailed procedures for fatigue precracking. Additional annexes are provided that give specific procedures for beryllium and rapid-force testing.

1.3 General information and requirements common to all specimen configurations:

Referenced Documents	Section
Terminology	2
Stress-Intensity Factor	3
Plane-Strain Fracture Toughness	3.1.1
Crack Plane Orientation	3.1.2
	3.1.4

¹ This test method is under the jurisdiction of ASTM Committee E08 on Fatigue and Fracture and is the direct responsibility of Subcommittee E08.07 on Fracture Mechanics.

Current edition approved Nov. 15, 2012. Published January 2013. Originally approved in 1970. Last previous edition approved in 2009 as E399 – 09^{ε2}. DOI: 10.1520/E0399-12E02.

² For additional information relating to the fracture toughness testing of aluminum alloys, see Practice B645.

³ The boldface numbers in parentheses refer to the list of references at the end of this standard.

Summary of Test Method	4
Significance and Use	5
Significance	5.1
Precautions	5.1.1 – 5.1.5
Practical Applications	5.2
Apparatus (see also 1.4)	6
Tension Machine	6.1
Fatigue Machine	6.2
Loading Fixtures	6.3
Displacement Gage, Measurement	6.4
Specimen Size, Configurations, and Preparation (see also 1.5)	7
Specimen Size Estimates	7.1
Standard and Alternative Specimen Configurations	7.2
Fatigue Crack Starter Notches	7.3.1
Fatigue Precracking (see also 1.6)	7.3.2
Crack Extension Beyond Starter Notch	7.3.2.2
General Procedure	8
Specimen Measurements	
Thickness	8.2.1
Width	8.2.2
Crack Size	8.2.3
Crack Plane Angle	8.2.4
Specimen Testing	
Loading Rate	8.3
Test Record	8.4
Calculation and Interpretation of Results	9
Test Record Analysis	9.1
P_{max}/P_Q Validity Requirement	9.1.3
Specimen Size Validity Requirements	9.1.4
Reporting	10
Precision and Bias	11

1.4 Specific requirements related to test apparatus:

Double-Cantilever Displacement Gage	Annex A1
Testing Fixtures	Annex A2
Bend Specimen Loading Fixture	Annex A2.1
Compact Specimen Loading Clevis	Annex A2.2

1.5 Specific requirements related to individual specimen configurations:

Bend Specimen $SE(B)$	Annex A3
Compact Specimen $C(T)$	Annex A4
Disk-Shaped Compact Specimen $DC(T)$	Annex A5
Arc-Shaped Tension Specimen $A(T)$	Annex A6
Arc-Shaped Bend Specimen $A(B)$	Annex A7

1.6 Specific requirements related to special test procedures:

Fatigue Precracking K_{IC} Specimens
Hot-Pressed Beryllium Testing
Rapid-Force Testing

Annex A8
Annex A9
Annex A10

1.7 The values stated in SI units are to be regarded as the standard. The values given in parentheses are for information only.

1.8 *This standard does not purport to address all of the safety concerns, if any, associated with its use. It is the responsibility of the user of this standard to establish appropriate safety and health practices and determine the applicability of regulatory limitations prior to use.*

2. Referenced Documents

2.1 ASTM Standards:⁴

- B909** Guide for Plane Strain Fracture Toughness Testing of Non-Stress Relieved Aluminum Products
- B645** Practice for Linear-Elastic Plane-Strain Fracture Toughness Testing of Aluminum Alloys
- E4** Practices for Force Verification of Testing Machines
- E8/E8M** Test Methods for Tension Testing of Metallic Materials
- E177** Practice for Use of the Terms Precision and Bias in ASTM Test Methods
- E337** Test Method for Measuring Humidity with a Psychrometer (the Measurement of Wet- and Dry-Bulb Temperatures)
- E456** Terminology Relating to Quality and Statistics
- E691** Practice for Conducting an Interlaboratory Study to Determine the Precision of a Test Method
- E1820** Test Method for Measurement of Fracture Toughness
- E1823** Terminology Relating to Fatigue and Fracture Testing
- E1921** Test Method for Determination of Reference Temperature, T_o , for Ferritic Steels in the Transition Range

3. Terminology

3.1 *Definitions:* Terminology **E1823** is applicable to this test method:

3.1.1 *stress-intensity factor, K, K_I, K_{II}, K_{III}* [FL^{-3/2}]—magnitude of the ideal-crack-tip stress field (a stress-field singularity), for a particular mode of crack displacement, in a homogeneous, linear-elastic body.

3.1.1.1 *K* is a function of applied force and test specimen size, geometry, and crack size, and has the dimensions of force times length^{-3/2}.

3.1.1.2 Values of *K* for modes I, II, and III are given as:

$$K_I = \lim_{r \rightarrow 0} [\sigma_{yy}(2\pi r)^{1/2}] \quad (1)$$

$$K_{II} = \lim_{r \rightarrow 0} [\tau_{xy}(2\pi r)^{1/2}] \quad (2)$$

⁴ For referenced ASTM standards, visit the ASTM website, www.astm.org, or contact ASTM Customer Service at service@astm.org. For *Annual Book of ASTM Standards* volume information, refer to the standard's Document Summary page on the ASTM website.

$$K_{III} = \lim_{r \rightarrow 0} [\tau_{yz}(2\pi r)^{1/2}] \quad (3)$$

where *r* is the distance directly forward from the crack tip to the location where the significant stress is calculated.

3.1.2 *plane-strain fracture toughness, K_{IC}* [FL^{-3/2}]—the crack-extension resistance under conditions of crack-tip plane strain in Mode I for slow rates of loading under predominantly linear-elastic conditions and negligible plastic-zone adjustment. The stress intensity factor, *K_{IC}*, is measured using the operational procedure (and satisfying all of the validity requirements) specified in Test Method E399, that provides for the measurement of crack-extension resistance at the onset (2% or less) of crack extension and provides operational definitions of crack-tip sharpness, onset of crack extension, and crack-tip plane strain.

3.1.2.1 See also definitions of crack-extension resistance, crack-tip plane strain, and mode in Terminology **E1823**.

3.1.3 *crack mouth opening displacement (CMOD), V_m* [L]—crack opening displacement resulting from the total deformation (elastic plus plastic), measured under force at the location on a crack surface that has the largest displacement per unit force.

3.1.4 *crack plane orientation*—identification of the plane and direction of crack extension in relation to the characteristic directions of the product. A hyphenated code defined in Terminology **E1823** is used wherein the letter(s) preceding the hyphen represents the direction normal to the crack plane and the letter(s) following the hyphen represents the anticipated direction of crack extension (see Fig. 1).

3.1.4.1 *Wrought Products*—the fracture toughness of wrought material depends on, among other factors, the orientation and propagation direction of the crack in relation to the material's anisotropy, which depends, in turn, on the principal directions of mechanical working and grain flow. Orientation of the crack plane shall be identified wherever possible. In addition, product form shall be identified (for example, straight-rolled plate, cross-rolled plate, pancake forging, and so forth) along with material condition (for example, annealed, solution treated plus aged, and so forth). The user shall be referred to product specifications for detailed processing information.

3.1.4.2 For rectangular sections, the reference directions are identified as in Fig. 1(a) and Fig. 1(b), which give examples for rolled plate. The same system is used for sheet, extrusions, and forgings with nonsymmetrical grain flow.

- L = direction of principal deformation (maximum grain flow)
- T = direction of least deformation
- S = third orthogonal direction

3.1.4.3 Using the two-letter code, the first letter designates the direction normal to the crack plane, and the second letter the expected direction of crack propagation. For example, in Fig. 1(a), the T-L specimen fracture plane normal is in the width direction of a plate and the expected direction of crack propagation is coincident with the direction of maximum grain flow (or longitudinal) direction of the plate.

3.1.4.4 For specimens tilted in respect to two of the reference axes as in Fig. 1(b), crack plane orientation is identified

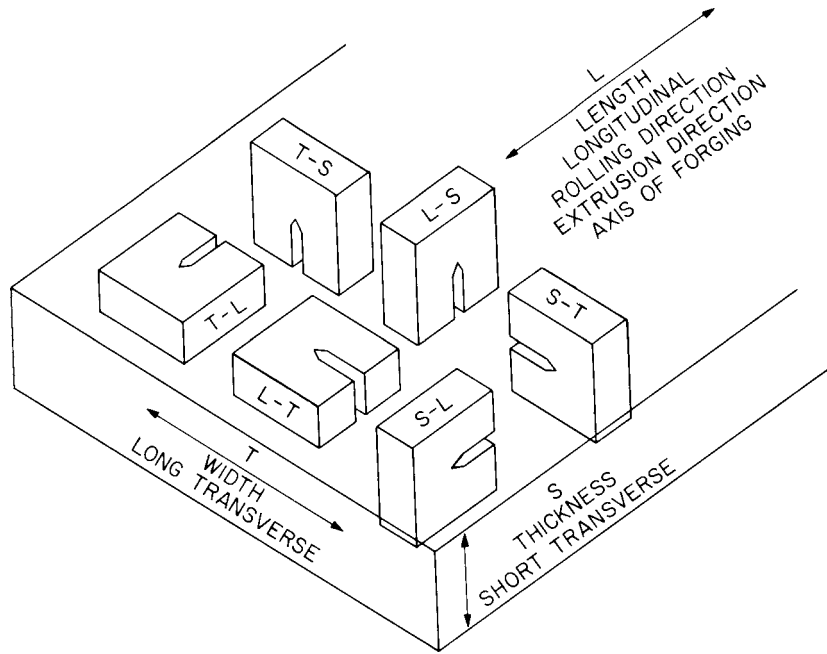

(a) Rectangular Sections—Specimens Aligned with Reference Directions

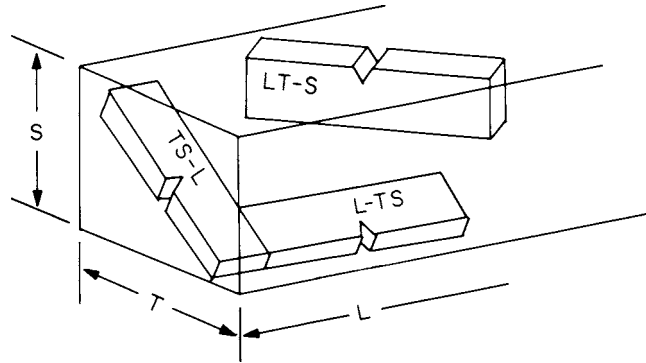

(b) Rectangular Sections—Specimens Not Aligned with Reference Directions

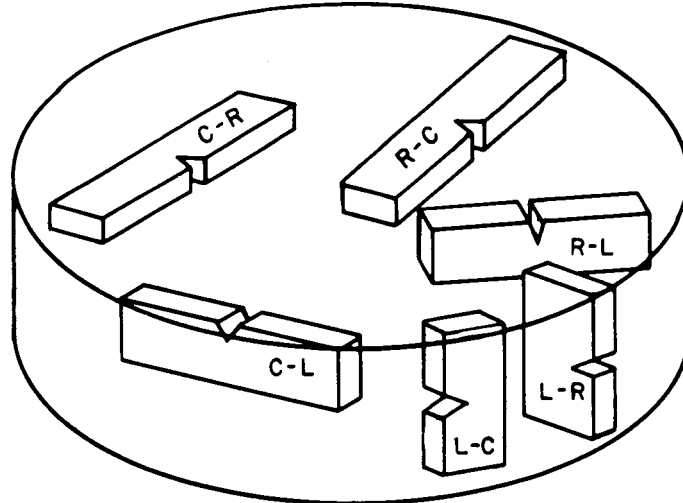

(c) Cylindrical Bars and Tubes

L = direction of maximum grain flow
 R = radial direction
 C = circumferential or tangential direction

FIG. 1 Crack Plane Identification

by a three-letter code. The designation L-TS, for example, indicates the crack plane to be perpendicular to the principal deformation (L) direction, and the expected fracture direction to be intermediate between T and S. The designation TS-L means that the crack plane is perpendicular to a direction intermediate between T and S, and the expected fracture direction is in the L direction.

3.1.4.5 For cylindrical sections, where grain flow can be in the longitudinal, radial or circumferential direction, specimen location and crack plane orientation shall reference original cylindrical section geometry such that the L direction is always the axial direction for the L-R-C system, as indicated in Fig. 1(c), regardless of the maximum grain flow. Note that this is a geometry based system. As such, the direction of maximum grain flow shall be reported when the direction is known.

NOTE 2—The same system is useful for extruded or forged parts having circular cross section. In most cases the L direction corresponds to the direction of maximum grain flow, but some products such as pancake, disk, or ring forgings can have the R or C directions correspond to the direction of maximum grain flow, depending on the manufacturing method.

L = axial direction
R = radial direction
C = circumferential or tangential direction

3.1.4.6 In the case of complex structural shapes, where the grain flow is not uniform, specimen location and crack plane orientation shall reference host product form geometry and be noted on component drawings.

3.1.4.7 *Non-Wrought Products*—for non-wrought products, specimen location and crack plane orientation shall be defined on the part drawing. The result of a fracture toughness test from a non-wrought product shall not carry an orientation designation.

3.1.4.8 *Discussion*—when products are to be compared on the basis of fracture toughness, it is essential that specimen location and orientation with respect to product characteristic directions be comparable and that the results not be generalized beyond these limits.

3.2 Definitions of Terms Specific to This Standard:

3.2.1 *stress-intensity factor rate, \dot{K} (FL^{-3/2} t⁻¹)*—change in stress-intensity factor, K , per unit time.

4. Summary of Test Method

4.1 This test method covers the determination of the plane-strain fracture toughness (K_{Ic}) of metallic materials by increasing-force tests of fatigue precracked specimens. Force is applied either in tension or three-point bending. Details of the test specimens and experimental procedures are given in the Annexes. Force versus crack-mouth opening displacement (CMOD) is recorded either autographically or digitally. The force at a 5 % secant offset from the initial slope (corresponding to about 2.0 % apparent crack extension) is established by a specified deviation from the linear portion of the record (1). The value of K_{Ic} is calculated from this force using equations that have been established by elastic stress analysis of the specimen configurations specified in this test method. The validity of the K_{Ic} value determined by this test method depends upon the establishment of a sharp-crack condition at the tip of the fatigue crack in a specimen having a size adequate

to ensure predominantly linear-elastic, plane-strain conditions. To establish the suitable crack-tip condition, the stress-intensity factor level at which specimen fatigue precracking is conducted is limited to a relatively low value.

4.2 The specimen size required for test validity increases as the square of the material's toughness-to-yield strength ratio. Therefore a range of proportional specimens is provided.

5. Significance and Use

5.1 The property K_{Ic} determined by this test method characterizes the resistance of a material to fracture in a neutral environment in the presence of a sharp crack under essentially linear-elastic stress and severe tensile constraint, such that (1) the state of stress near the crack front approaches triaxial plane strain, and (2) the crack-tip plastic zone is small compared to the crack size, specimen thickness, and ligament ahead of the crack.

5.1.1 Variation in the value of K_{Ic} can be expected within the allowable range of specimen proportions, a/W and W/B . K_{Ic} may also be expected to rise with increasing ligament size. Notwithstanding these variations, however, K_{Ic} is believed to represent a lower limiting value of fracture toughness (for 2 % apparent crack extension) in the environment and at the speed and temperature of the test.

5.1.2 Lower values of K_{Ic} can be obtained for materials that fail by cleavage fracture; for example, ferritic steels in the ductile-to-brittle transition region or below, where the crack front length affects the measurement in a stochastic manner independent of crack front constraint. The present test method does not apply to such materials and the user is referred to Test Method E1921 and E1820. Likewise this test method does not apply to high toughness or high tearing-resistance materials whose failure is accompanied by appreciable amounts of plasticity. Guidance on testing elastic-plastic materials is given in Test Method E1820.

5.1.3 The value of K_{Ic} obtained by this test method may be used to estimate the relation between failure stress and crack size for a material in service wherein the conditions of high constraint described above would be expected. Background information concerning the basis for development of this test method in terms of linear elastic fracture mechanics may be found in Refs (1) and (2).

5.1.4 Cyclic forces can cause crack extension at K_I values less than K_{Ic} . Crack extension under cyclic or sustained forces (as by stress corrosion cracking or creep crack growth) can be influenced by temperature and environment. Therefore, when K_{Ic} is applied to the design of service components, differences between laboratory test and field conditions shall be considered.

5.1.5 Plane-strain fracture toughness testing is unusual in that there can be no advance assurance that a valid K_{Ic} will be determined in a particular test. Therefore, compliance with the specified validity criteria of this test method is essential.

5.1.6 Residual stresses can adversely affect the indicated K_Q and K_{Ic} values. The effect can be especially significant for specimens removed from as-heat treated or otherwise non-stress relieved stock, from weldments, from complex wrought parts, or from parts with intentionally induced residual stresses.

Indications of residual stress include distortion during specimen machining, results that are specimen configuration dependent, and irregular fatigue precrack growth (either excessive crack front curvature or out-of-plane growth). Guide B909 provides supplementary guidelines for plane strain fracture toughness testing of aluminum alloy products for which complete stress relief is not practicable. Guide B909 includes additional guidelines for recognizing when residual stresses may be significantly biasing test results, methods for minimizing the effects of residual stress during testing, and guidelines for correction and interpretation of data.

5.2 This test method can serve the following purposes:

5.2.1 In research and development, to establish in quantitative terms significant to service performance, the effects of metallurgical variables such as composition or heat treatment, or of fabricating operations such as welding or forming, on the fracture toughness of new or existing materials.

5.2.2 In service evaluation, to establish the suitability of a material for a specific application for which the stress conditions are prescribed and for which maximum flaw sizes can be established with confidence.

5.2.3 For specifications of acceptance and manufacturing quality control, but only when there is a sound basis for specifying minimum K_{Ic} values, and then only if the dimensions of the product are sufficient to provide specimens of the size required for valid K_{Ic} determination. The specification of K_{Ic} values in relation to a particular application should signify that a fracture control study has been conducted for the component in relation to the expected loading and environment, and in relation to the sensitivity and reliability of

the crack detection procedures that are to be applied prior to service and subsequently during the anticipated life.

6. Apparatus

6.1 *Testing Machine and Force Measurement*—The calibration of the testing machine shall be verified in accordance with Practices E4. The test machine shall have provisions for autographic recording of the force applied to the specimen; or, alternatively, a computer data acquisition system that may be used to record force and CMOD for subsequent analysis.

6.2 *Fatigue Precracking Machine*—When possible, the calibration of the fatigue machine and force-indicating device shall be verified statically in accordance with Practices E4. If the machine cannot be calibrated and verified statically, the applied force shall otherwise be known to $\pm 2.5\%$. Careful alignment of the specimen and fixturing is necessary to encourage straight fatigue cracks. The fixturing shall be such that the stress distribution is uniform across the specimen thickness and symmetrical about the plane of the prospective crack.

6.3 *Loading Fixtures*—Fixtures suitable for loading the specified specimen configurations are shown in the Annexes. The fixtures are designed to minimize friction contributions to the measured force.

6.4 *Displacement Gage*—The displacement gage electrical output represents relative displacement (V) of two precisely located gage positions spanning the crack starter notch mouth. Exact and positive positioning of the gage on the specimen is essential, yet the gage must be released without damage when

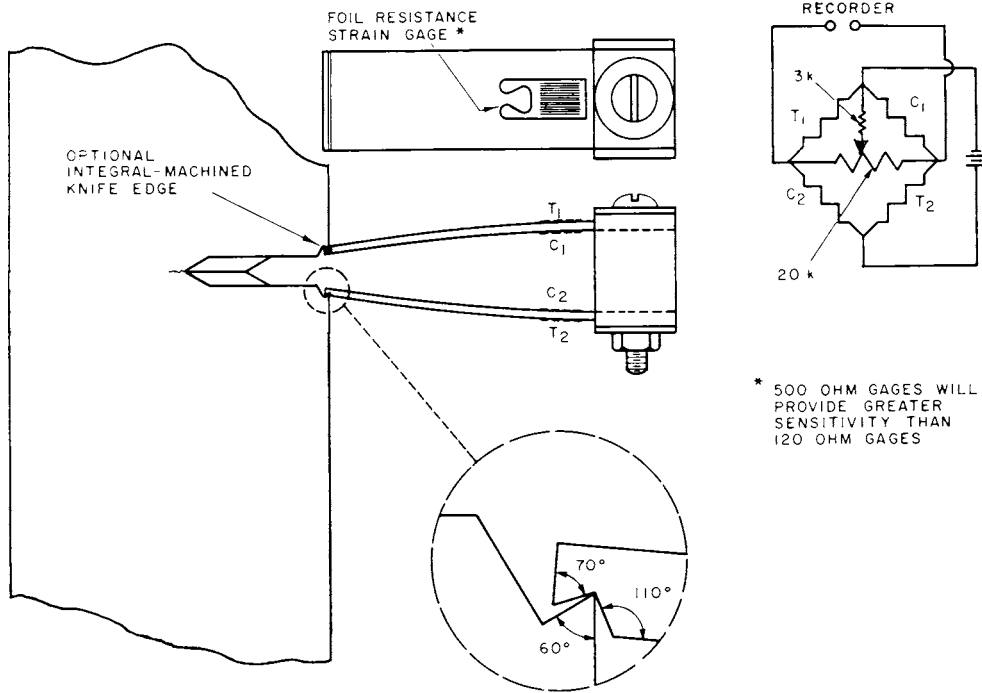

NOTE—Gage details are given in the Annex.

FIG. 2 Double-Cantilever Clip-In Displacement Gage Showing Mounting by Means of Integral Knife Edges (Gage Design Details are Given in Annex A1)

the specimen breaks. Displacement gage and knife-edge designs shall provide for free rotation of the points of contact between the gage and the specimen. A recommended design for a self-supporting, releasable displacement gage is shown in Fig. 2 and described in Annex A1. The gage's strain gage bridge arrangement is also shown in Fig. 2.

6.4.1 The specimen shall be provided with a pair of accurately machined knife edges to support the gage arms and serve as displacement reference points. The knife edges may be machined integral with the specimen as shown in Figs. 2 and 3, or they may be separate pieces affixed to the specimen. A suggested design for attachable knife edges is shown in Fig. 4. This design features a knife edge spacing of 5 mm (0.2 in.). The effective gage length is established by the points of contact between the screw and the hole threads. For the design shown, the major diameter of the screw is used in setting this gage length. A No. 2 screw will permit the use of attachable knife edges for specimens having $W > 25$ mm (1.0 in.).

6.4.2 Each gage shall be verified for linearity using an extensometer calibrator or other suitable device. The resolution of the calibrator at each displacement interval shall be within 0.00051 mm (0.000020 in.). Readings shall be taken at ten equally spaced intervals over the working range of the gage (see Annex A1). The verification procedure shall be performed three times, removing and reinstalling the gage in the calibration fixture after each run. The required linearity shall correspond to a maximum deviation of 0.003 mm (0.0001 in.) of the individual displacement readings from a least-squares-best-fit straight line through the data. The absolute accuracy, as such, is not important in this application, since the test method is concerned with relative changes in displacement rather than absolute values (see 9.1). Verification of gage calibration shall be performed at the temperature of test $\pm 5.6^\circ\text{C}$ (10°F). The gage shall be verified during the time the gage is in use at time

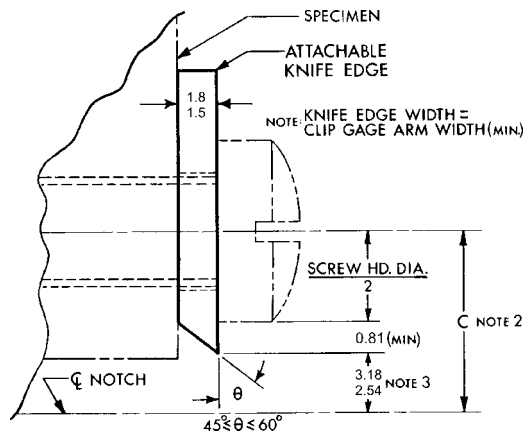

NOTE 1—Dimensions are in mm.
 NOTE 2—Effective gage length = $2C + \text{Screw Thread Diameter} \leq W/2$. (This will always be greater than the gage length specified in A1.1.)
 NOTE 3—Dimension shown corresponds to clip gage spacer block dimension in Annex A1.

Inch-Pound Units Equivalents					
mm	0.81	1.5	1.8	2.54	3.18
in.	0.032	0.060	0.070	0.100	0.125

FIG. 4 Example of Attachable Knife Edge Design

intervals defined by established quality assurance practices. Commercial gages are typically verified annually.

6.4.3 It is not the intent of this test method to exclude the use of other types of gages or gage-fixing devices provided the gage used meets the requirements listed above and provided the gage length does not exceed those limits given in the Annex appropriate to the specimen being tested.

7. Specimen Size, Configurations, and Preparation

7.1 Specimen Size:

7.1.1 In order for a result to be considered valid according to this test method (see also 3.1.2.1), the specimen ligament size ($W - a$) must be not less than $2.5(K_{Ic}/\sigma_{YS})^2$, where σ_{YS} is the 0.2 % offset yield strength of the material in the environment and orientation, and at the temperature and loading rate of the test (1, 3, 4). For testing at rates other than quasi-static see Annex A10, Rapid Force Testing. The specimen must also be of sufficient thickness, B , to satisfy the specimen proportions in 7.2.1 or 7.2.1.1 and meet the P_{max}/P_Q requirement in 9.1.3. Meeting the ligament size and P_{max}/P_Q requirements cannot be assured in advance. Thus, specimen dimensions shall be conservatively selected for the first test in a series. If the form of the material available is such that it is not possible to obtain a test specimen with ligament size equal to or greater than $2.5(K_{Ic}/\sigma_{YS})^2$, then it is not possible to make a valid K_{Ic} measurement according to this test method.

7.1.2 The initial selection of specimen size for a valid K_{Ic} measurement is often based on an estimated value of K_{Ic} for the material.

7.1.3 Alternatively, the ratio of yield strength to elastic modulus may be used for selecting a specimen size that will be adequate for all but the toughest materials:

$$\sigma_{YS}/E$$

Minimum Recommended
Ligament Size
mm in.

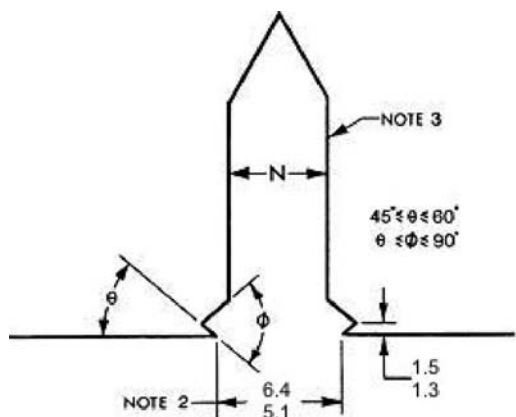

NOTE 1—Dimensions in mm.

NOTE 2—Gage length shown corresponds to clip gage spacer block dimensions shown in Annex A1, but other gage lengths may be used provided they are appropriate to the specimen (see 6.4.3).

NOTE 3—For starter notch configurations see Fig. 5.

Inch-Pound Units Equivalents				
mm	1.3	1.5	5.08	6.35
in.	0.050	0.060	0.200	0.250

FIG. 3 Example of Integral Knife Edge Design

0.0050 to 0.0057	76	3
0.0057 to 0.0062	64	2½
0.0062 to 0.0065	51	2
0.0065 to 0.0068	44	1¾
0.0068 to 0.0071	38	1½
0.0071 to 0.0075	32	1¼
0.0075 to 0.0080	25	1
0.0080 to 0.0085	19	¾
0.0085 to 0.0100	13	½
0.0100 or greater	6.4	¼

When it has been established that $2.5(K_{Ic}/\sigma_{YS})^2$ is substantially less than the minimum recommended ligament size given in the preceding table, then a correspondingly smaller specimen can be used.

7.2 Specimen Configurations—Recommended specimen configurations are shown in Figs. A3.1-A6.1 and Fig. A7.1.

7.2.1 Specimen Proportions—Crack size, a , is nominally between 0.45 and 0.55 times the width, W . Bend specimens can have a width to thickness, W/B , ratio of $1 \leq W/B \leq 4$. Tension specimen configurations can be $2 \leq W/B \leq 4$.

7.2.1.1 Recommended Proportions—It is recommended that the thickness, B , is nominally one-half the specimen width, W

(that is, $W/B = 2$). Likewise, the crack size, a , should be nominally equal to one-half the width, W (that is $a/W = 1/2$).

NOTE 3—Alternative W/B ratios different from the recommended ratio in 7.2.1.1 but still meeting the requirements in 7.2.1 are sometimes useful, especially for quality control or lot releases purposes, because they allow a continuous range of product thicknesses to be tested using a discrete number of specimen widths while still maintaining specimens of full product thickness. However, because specimen width influences the amount of crack extension corresponding to the 95 % slope, K_{Ic} obtained with alternative W/B ratios may not agree with those obtained using the recommended W/B ratio, particularly in products exhibiting a Type I force-CMOD record (5). As an example, a specimen with the recommended proportion $W/B = 2$ would tend to yield a lower K_{Ic} than a specimen with an alternative proportion $W/B = 4$. Also, because a shorter ligament length may hinder resistance curve development, an alternative specimen with $W/B < 2$ (allowed only for bend specimens) may pass the P_{max}/P_Q requirement, while a specimen with the recommended W/B ratio would fail. Conversely, an alternative specimen with $W/B > 2$ (allowed in both tension and bend specimens) may fail the P_{max}/P_Q requirement, while a specimen with the recommended W/B would pass.

7.2.2 Alternative Specimens—In certain cases it may be necessary or desirable to use specimens having W/B ratios other than that specified in 7.2.1. Alternative W/B ratios and

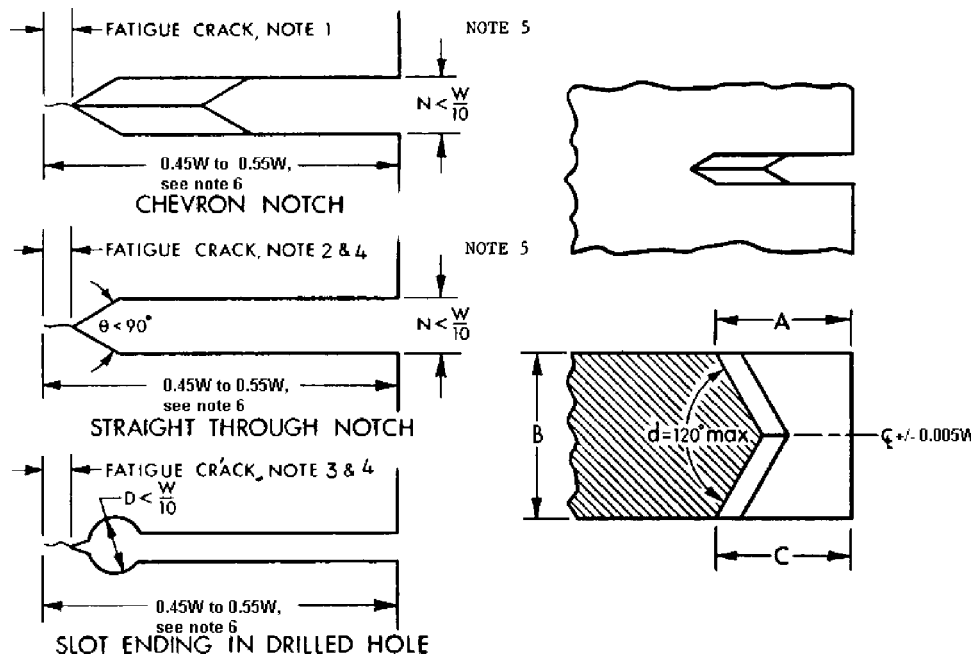

(a) Starter Notches and Fatigue Cracks

(b) Detail of Chevron Notch

- Note 1—For a chevron crack starter notch the fatigue crack shall emerge on both surfaces of the specimen.
- Note 2—Fatigue crack extension on each surface of the specimen containing a straight-through notch shall be at least 0.025 W or 1.3 mm (0.050 in.), whichever is larger.
- Note 3—Fatigue crack extension on each surface of the specimen from the stress raiser tipping the hole shall be at least 0.5 D or 1.3 mm (0.050 in.), whichever is larger.
- Note 4—Crack starter notch shall be perpendicular to the specimen surfaces and to the intended direction of crack propagation within $\pm 2^\circ$.
- Note 5—Notch width N need not be less than 1.6 mm ($1/16$ in.).
- Note 6—From notched edge or centerline of loading holes, as appropriate.

- Note 1— $A = C$ within 0.010 W .
- Note 2—Cutter tip angle 90° max.
- Note 3—Radius at chevron notch bottom 0.25 mm (0.010 in.) max.

FIG. 5 Crack Starter Notch and Fatigue Crack Configurations

side-grooved specimens are allowed as specified in 7.2.1.1 and 7.2.2.1. These alternative specimens shall have the same crack length-to-specimen width ratio as the standard specimen.

7.2.2.1 *Alternative Side-Grooved Specimens*—For the compact C(T) and the bend SE(B) specimen configurations side-grooving is allowed as an alternative to plain-sided specimens. The total thickness reduction shall not exceed $0.25 B$. A total reduction of $0.20 B$ has been found to work well (6) for many materials and is recommended (10% per side). Any included angle less than 90° is allowed. The root radius shall be 0.5 ± 0.2 mm (0.02 ± 0.01 in.). Precracking prior to the side-grooving operation is recommended to produce nearly straight fatigue precrack fronts. B_N is the minimum thickness measured at the roots of the side grooves. The root of the side groove shall be located along the specimen centerline. Fig. 6 is a schematic showing an example cross section of an alternative side grooved specimen.

NOTE 4—Side-grooves increase the level of constraint with respect to the recommended specimen. The increased constraint promotes a more uniform stress state along the crack front and inhibits shear lip development. As a result, the K_{Ic} value from a side-grooved specimen is expected to be lower than the K_{Ic} obtained from the recommended specimen, particularly for thin products or products exhibiting Type I behavior. The value of K_{Ic} from a side-grooved specimen may better represent the fracture toughness of the material in structural situations where plasticity is more highly constrained by the crack front geometry such as may be the case for a surface or corner crack, or by structural details such as keyways, radii, notches, etc. The value of K_{Ic} from the recommended specimen may better represent the fracture toughness of the material in structural situations where surface plasticity and shear lip development is not constrained such as a through crack in a region of uniform thickness. Side-grooving increases the likelihood of meeting the P_{max}/P_Q requirement, enabling a valid K_{Ic} to be obtained in products for which it would not be possible using the recommended specimen. Side grooving after precracking beneficially removes a portion of the non-linear crack front at the ends of the crack front, thus increasing the likelihood of meeting crack front straightness requirements. However, side grooving may also remove material that influences service performance. This is often true for cast parts and those for which thermo-mechanical working is part of the heat treating cycle. The increased constraint also can lead to increased likelihood of material delamination, for instance, in the plane of the specimen, which could lead to test results different from those obtained from plane-sided specimens.

NOTE 5—No interlaboratory ‘round robin’ test program has yet been conducted to compare the performance of plain-sided and side-grooved specimens. However, the results of several studies (6) indicate that K_{Ic} from side-grooved specimens is zero to 10 % less than that of plain-sided specimens, the difference increasing with increasing material toughness. The within-laboratory repeatability was determined according to the conditions in Terminology E456 and the results are presented in 11.3.

7.2.2.2 For lot acceptance testing, side-grooved specimens shall not be used unless specifically allowed by the product specification or by agreement between producer and user.

7.3 *Specimen Preparation*—All specimens shall be tested in the finally heat-treated, mechanically-worked, and environmentally-conditioned state. Specimens shall normally be machined in this final state. However, for material that cannot be machined in the final condition, the final treatment may be carried out after machining provided that the required dimensions and tolerances on specimen size, shape, and overall finish are met (see specimen drawings of Figs. A3.1-A6.1 and Fig. A7.1), and that full account is taken of the effects of specimen size on metallurgical condition induced by certain heat treatment procedures; for example, water quenching of steels.

7.3.1 *Fatigue Crack Starter Notch*—Three fatigue crack starter notch configurations are shown in Fig. 5. To facilitate fatigue precracking at low stress intensity levels, the suggested root radius for a straight-through slot terminating in a V-notch is 0.08 mm (0.003 in.) or less. For the chevron form of notch, the suggested root radius is 0.25 mm (0.010 in.) or less. For the slot ending in a drilled hole, it is necessary to provide a sharp stress raiser at the end of the hole. Care shall be taken to ensure that this stress raiser is so located that the crack plane orientation requirements of 8.2.4 can be met.

7.3.2 *Fatigue Precracking*—Fatigue precracking procedures are described in Annex A8. Fatigue cycling is continued until a crack is produced that satisfies the requirements of 7.3.2.1 and 7.3.2.2 that follow.

7.3.2.1 Crack size (total size of crack starter plus fatigue crack) shall be between $0.45W$ and $0.55W$.

7.3.2.2 The size of the fatigue crack on each face of the specimen shall not be less than the larger of $0.025W$ or 1.3 mm (0.050 in.) for the straight-through crack starter configuration, not less than the larger of $0.5D$ or 1.3 mm (0.050 in.) for the slot ending in a hole (of diameter $D < W/10$), and need only emerge from the chevron starter configuration.

8. General Procedure

8.1 *Number of Tests*—It is recommended that triplicate tests, minimum, be made for each material condition.

8.2 *Specimen Measurement*—Specimen dimensions shall conform to the drawings of Figs. A3.1-A6.1 and Fig. A7.1. Measurements essential to the calculation of K_{Ic} are specimen

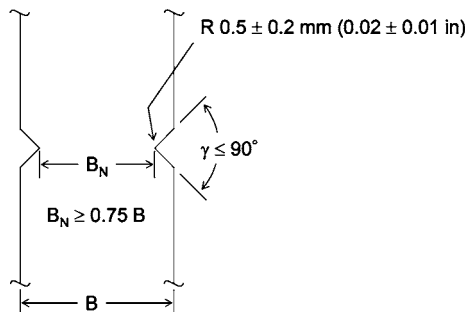

FIG. 6 Schematic of Side Groove Configuration

thickness, B (and in the case of side-grooved alternative specimens, B_N), crack size, a , and width, W .

8.2.1 Specimen thickness, B (and in the case of side-grooved alternative specimens, B_N), shall be measured before testing to the nearest 0.03 mm (0.001 in.) or to 0.1 %, whichever is larger. For plain-sided specimens, B shall be measured adjacent the notch. For side-grooved specimens, B_N shall be measured at the root of the notch and B adjacent the notch.

NOTE 6—For plane-sided specimens the value of B_N is equal to the thickness B .

8.2.2 Specimen width, W , shall be measured, in conformance with the procedure of the annex appropriate to the specimen configuration, to the nearest 0.03 mm (0.001 in.) or 0.1 %, whichever is larger, at not less than three positions near the notch location, and the average value recorded.

8.2.3 Specimen crack size, a , shall be measured after fracture to the nearest 0.5 % at mid-thickness and the two quarter-thickness points (based on B for plain-sided specimens and B_N for side-grooved specimens). The average of these three measurements shall be taken as the crack size, a . The difference between any two of the three crack size measurements shall not exceed 10 % of the average. The crack size shall be measured also at each surface. For the straight-through notch starter configuration, no part of the crack front shall be closer to the machined starter notch than 0.025 W or 1.3 mm (0.050 in.), whichever is larger; furthermore, neither surface crack size measurement shall differ from the average crack size by more than 15 % and their difference shall not exceed 10 % of the average crack size. For the chevron notch starter configuration, the fatigue crack shall emerge from the chevron on both surfaces; furthermore, neither surface crack size measurement shall differ from the average crack size by more than 15 %, and their difference shall not exceed 10 % of the average crack size.

8.2.4 The plane of the fatigue precrack and subsequent 2 % crack extension (in the central flat fracture area; that is, excluding surface shear lips) shall be parallel to the plane of the starter notch to $\pm 10^\circ$. For side-grooved specimens, the plane of the fatigue precrack and subsequent 2 % crack extension shall be within the root of the side-groove.

8.2.5 There shall be no evidence of multiple cracking (that is, more than one crack) (7).

8.3 *Loading Rate*—For conventional (quasi-static) tests, the specimen shall be loaded such that the rate of increase of stress-intensity factor is between 0.55 and 2.75 MPa $\sqrt{\text{m/s}}$ (30 and 150 ksi $\sqrt{\text{in./min}}$) during the initial elastic displacement. Loading rates corresponding to these stress-intensity factor rates are given in the Annex appropriate to the specimen being tested. For rapid-force tests, loading rates are to be as specified in Annex A10.

8.4 *Test Record*—A record shall be made of the output of the force-sensing transducer versus the output of the displacement gage. The data acquisition system shall be set such that not less than 50 % of full range is used for the test record. If an autographic recorder is used, it shall be adjusted such that the slope of the initial portion of the force-CMOD record is between 0.7 and 1.5. Alternatively, if a computer data acquisition system is used, it shall be programmed to capture enough data to permit the calculations of Section 9.

8.4.1 The test shall be continued until the specimen can sustain no further increase in applied force. The maximum force (P_{max}) shall be noted and recorded.

9. Calculation and Interpretation of Results

9.1 *Interpretation of Test Record and Calculation of K_{Ic}* —In order to substantiate the validity of a K_{Ic} determination, it is first necessary to calculate a conditional result, K_Q , which involves a construction on the test record, and then to determine whether this result is consistent with the size and yield strength of the specimen according to 7.1. The procedure is as follows:

9.1.1 When an autographic recorder is used, the conditional value P_Q is determined by drawing the secant line OP_5 , (see Fig. 7) through the origin (point O) of the test record with slope $(P/V)_5$ equal to $0.95(P/V)_o$, where $(P/V)_o$ is the slope of the tangent OA to the initial linear portion of the record (Note 7). In practice the origin (point O) is not necessarily at the intersection of the displacement- and force-axes. The point O lies on the best fit line through the initial linear portion of the record and at the intersection of the best fit line with the displacement-axis. Thus, in calculating the secant line OP_5 , the rotation point of the slope adjustment should be at the intersection of the line OA with the displacement-axis. The force P_Q is then defined as follows: if the force at every point on the record which precedes P_5 is lower than P_5 (Fig. 7, Type I), then P_5 is P_Q ; if, however, there is a maximum force preceding P_5 which exceeds it (Fig. 7, Types II and III), then this maximum force is P_Q .

NOTE 7—Slight initial nonlinearity of the test record is frequently observed, and is to be ignored. However, it is important to establish the initial slope of the record with high precision. Therefore it is advisable to minimize this nonlinearity by preliminarily loading the specimen to a maximum force corresponding to a stress-intensity factor level not exceeding that used in the final stage of fatigue cracking, then unloading.

NOTE 8—Residual stresses can adversely affect the indicated K_Q and K_{Ic} values. The applied loading is superimposed on the residual stresses, resulting in a total crack tip stress-intensity different from that based solely on the externally applied forces. In addition, residual stresses will likely redistribute during machining when the specimen is extracted from the host material. Hence, the magnitude of their influence on K_Q and K_{Ic} in the test specimen may be quite different from that in the original or finish machined product (see also 5.1.6.)

9.1.2 When a computer data acquisition system is used, the data reduction program shall determine the same forces (P_Q and P_{max}) as above. The algorithms for doing this are discretionary.

9.1.3 The ratio P_{max}/P_Q , where P_{max} is the maximum force the specimen was able to sustain (see 8.4.1), shall be calculated. If this ratio does not exceed 1.10, proceed to calculate K_Q as described in the Annex appropriate to the specimen configuration. If P_{max}/P_Q does exceed 1.10, then the test is not a valid K_{Ic} test and the user is referred to Test Method E1820 on elastic-plastic fracture toughness.

9.1.4 The value $2.5(K_Q/\sigma_{YS})^2$, where σ_{YS} is the 0.2 % offset yield strength in tension (see Test Methods E8/E8M), shall be calculated. If this quantity is less than the specimen ligament size, $W-a$ then K_Q is equal to K_{Ic} . Otherwise, the test is not a

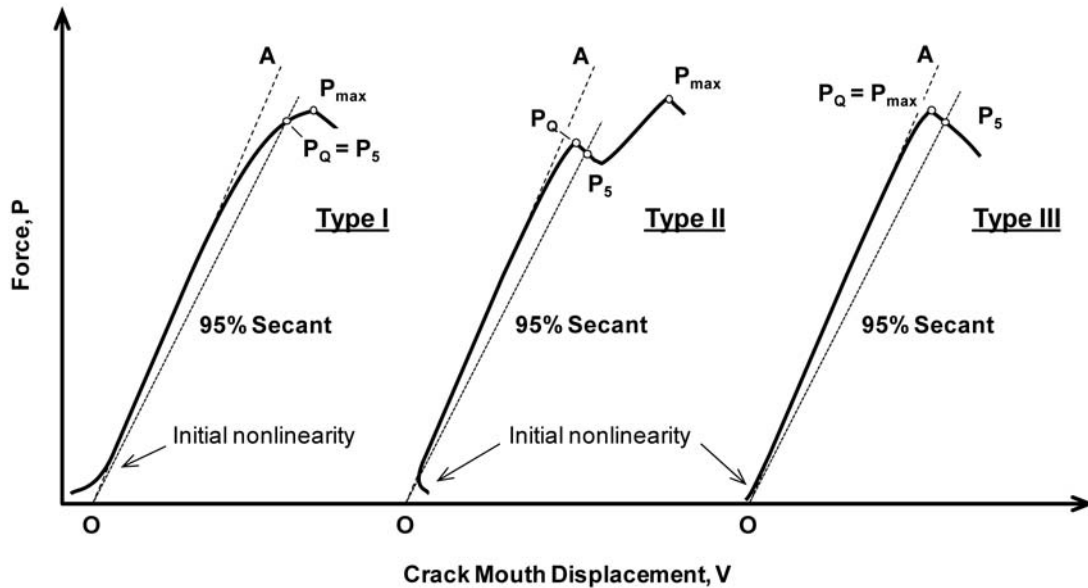

FIG. 7 Principal Types of Force-Displacement (CMOD) Records

valid K_{Ic} test. Expressions for calculating K_Q are given in the Annexes for each specified specimen configuration.

9.1.5 If the test result fails to meet the requirements of 9.1.3 or 9.1.4, or both, it will be necessary to use a larger specimen to determine K_{Ic} .

10. Report

10.1 The specimen configuration code shown on the specimen drawing (in the appropriate Annex) shall be reported. This code shall be followed with the loading code (T for tension, B for bending) and the code for crack plane orientation (see 3.1.4). The latter two codes shall appear in separate parentheses. As an example, a test result obtained using the compact specimen (see Annex A4) might be designated as follows: C(T)(S-T). The first letter (C) indicates the specimen to be a compact configuration. The second letter (T) denotes the loading as tension. The first of the two letters in the last bracket (S) indicates the normal to the crack plane to be normal to the direction of principal deformation. The second of these letters (T) indicates the intended direction of crack extension to be parallel with the direction of least deformation. For cylindrical sections, where grain flow can be in the longitudinal, radial or circumferential direction, the direction of maximum grain flow shall be reported when the direction is known (see 3.1.4).

10.2 The following information shall be additionally reported for each specimen tested:

10.2.1 Characterization of the material (alloy code or chemistry and metallurgical condition) and product form (sheet, plate, bar, forging, casting, and so forth) tested.

10.2.2 Specimen thickness, B , for plain-sided configurations. For side-grooved specimens, B , B_N and $(B \cdot B_N)^{1/2}$.

10.2.3 Specimen width (depth), W .

10.2.3.1 Loading hole offset, X , for the arc-shaped tension specimen.

10.2.3.2 Outer and inner radii, r_2 and r_1 , for arc-shaped specimens.

10.2.4 Fatigue precracking conditions, specifically the maximum stress-intensity factor, K_{max} , stress-intensity factor range, ΔK_I , and number of cycles for the final 2.5 % of the overall crack size, a (size of notch plus fatigue crack extension).

10.2.5 Crack size measurements, after fracture, at mid-thickness and the two quarter-thickness positions on the crack front, as well as at the intersection of the crack front with the specimen surface.

10.2.6 Test temperature.

10.2.7 Relative humidity as determined by Test Method E337.

10.2.8 Loading rate in terms of \dot{K}_I (change in stress-intensity factor per unit time) (2).

10.2.9 Force-versus-crack mouth opening displacement (CMOD) record and associated calculations.

10.2.10 Yield strength as determined by Test Methods E8/E8M.

10.2.11 K_{Ic} (or, K_Q followed by the parenthetical statement “invalid according to Sections(s) _____ of Test Method E399”).

10.2.12 P_{max}/P_Q .

10.3 Fig. 8 is a convenient format for tabulating the information required in 10.1 and 10.2.

11. Precision and Bias

11.1 The precision of K_{Ic} measurements has been examined in several interlaboratory round-robin studies. Selected aluminum alloys and high-strength steels were tested using standard bend SE(B) (8), compact C(T) (9), and arc-shaped tension A(T) (10) specimen configurations. The results are summarized in 11.3 (Precision) and 11.5 (Bias) that follow. Not all of the results reported satisfied all of the validity requirements of this test method. Statistical analysis (9, 10, 11) was used to exclude data that were likely influenced by deviations from the validity requirements. No round-robin program has been conducted for

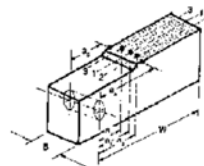

Figure 7. K_{Ic} Data Sheet (Example)

Material/Form _____ Heat Treat _____
 Specimen I.D. _____ Specimen Type _____

Date / /

PARTICULARS	DATA	REF. PARAGRAPH	FRACTURE TEST	DATA	REF. PARAGRAPH
Crack Plane Orientation		3.1.3	Crack Size		
Material Yield Strength, MPa (ksi)		7.1.1, A10.2.1, A10.7.3	- At Center of Crack Front (a_1) mm (in.)		8.2.3
Specimen Thickness, mm (in.)		8.2.1	- At Right of Center (a_2) mm (in.)		8.2.3
Specimen Width, mm (in.)		8.2.2	- At Left of Center (a_3) mm (in.)		8.2.3
---for SE (B)		A3.4.1	- At Right Surface (a_4) mm (in.)		8.2.3
---for C (T)		A4.4.1	- At Left Surface (a_5) mm (in.)		8.2.3
---for DC (T)		A5.4.1.2	Crack Plane Symmetry		8.2.4
Arc-Shaped Tension A (T) Specimen:			Loading Rate MPavm/s (ksiv/in./min)		8.3
---Width, W, mm (in.)		A6.4.1	Test Temperature °C (°F)		10.2.6
---Loading Plate Offset, X, mm (in.)		A6.4.1	Relatively Humidity, %		10.2.7
---Outer and Inner Radii r_1 and r_2 , mm (in.)		A6.4.1	Force-CMOD Record		8.4, 9.1
Arc-Shaped Bend A (B) Specimen:					
---Width, W, mm (in.)		A7.4.1			
---Loading Plate Offset, X, mm (in.)		A7.4.1			
---Outer and Inner Radii r_1 and r_2 , mm (in.)		A7.4.1			
FATIGUE PRECRACKING	DATA	REF. PARAGRAPH	K CALCULATION	DATA	REF. PARAGRAPH
--- $K_{max}/E < 0.00032 \sqrt{m}$ (0.002 $\sqrt{in.}$)		A8.3.3	$P_{max}/P_Q < 1.1$		9.1.3
--- $K_{max} < 0.6 K_Q$ MPa \sqrt{m} (ksiv/in.)		A8.3.3	--- $2.5(K_{Ic}/\sigma_{ys})^2$, MPa \sqrt{m} (ksiv/in.)		7.1, 9.1.4
--- $K_{max} < 0.8 K_{Ic}$ MPa \sqrt{m} (ksiv/in.)		A8.3.3	--- K_Q SE(B) MPa \sqrt{m} (ksiv/in.)		A3.5.3
-for Test at Temperature T_2 :			--- K_Q C(T) MPa \sqrt{m} (ksiv/in.)		A4.5.3
- $K_{MAX} T_1 < 0.6(\sigma_{ys(T1)}/\sigma_{ys(T2)}) K_Q (T_2)$ MPa \sqrt{m} (ksiv/in.)		A8.4.4	--- K_Q DC(T) MPa \sqrt{m} (ksiv/in.)		A5.5.3
Crack Size – Starter Slot Plus Fatigue Precrack:			--- K_Q A(T) MPa \sqrt{m} (ksiv/in.)		A6.5.3
--- $a = 0.50W$ mm (in.)		7.3.2.1, A8.3.2	--- K_Q A(B) MPa \sqrt{m} (ksiv/in.)		A7.5.3
--- $K_{MAX}, \Delta K$ MPa \sqrt{m} (ksiv/in.)		A8.1.3			
			Invalid according to E 399 Section(s):		10.2.11
			Valid K_{Ic} MPa \sqrt{m} (ksiv/in.):		10.2.11

FIG. 8 Suggested Form of Table for Reporting Information Listed in 10.1 and 10.2

the disk-shaped compact DC(T) specimen configuration, but limited data for that specimen configuration are compared with data for other specimen configurations in Annex A5. Round-robin studies specific to the quasi-static testing of beryllium and the dynamic testing of a strain-rate sensitive steel, and which involved special testing procedures, are presented in Annex A9 and Annex A10.

11.2 It should be emphasized that the measures of precision given in Table 1, Table 2, and Table 3 apply to alloys that essentially exhibited no transitional fracture behavior with temperature or strain rate under the specific test conditions of the interlaboratory studies.

11.3 Precision—The precision of K_{Ic} determination is affected by errors in the measurement of test force and specimen dimensions, especially the crack size. This test method specifies a precision for each measured quantity and, based on these specifications and the round-robin results, a theoretical precision is rendered (12). Analysis of the method’s specifications suggests that precision decreases with increasing relative crack size, more for the bend than for the compact configuration. In practice, the precision of K_{Ic} measurement may depend to an unknown extent on the characteristics of the test record and analysis skills of the laboratory personnel. It is possible to derive useful information concerning the precision of K_{Ic}

TABLE 1 Precision Using SE(B) Specimens (Nominal Crack Size-to-Specimen Width Ratio $a/W = 0.5$)

Parameter	Material and Yield Strength	Average	Repeatability Standard Deviation	Reproducibility Standard Deviation	Repeatability Limit	Reproducibility Limit
K_{Ic} (MPa \sqrt{m})	2219–T851 (353 MPa)	35.94	2.27	2.54	6.37	7.11
	Maraging 18Ni (1903 MPa)	57.02	2.15	4.03	6.03	11.27
	4340–500 F (1641 MPa)	48.55	1.86	2.17	5.20	6.07
	4340–800 F (1420 MPa)	87.76	3.03	4.13	8.49	11.56

TABLE 2 Precision Using C(T) Specimens (Nominal Crack Size-to-Specimen Width Ratio $a/W = 0.5$)

Parameter	Material and Yield Strength	Average	Repeatability Standard Deviation	Reproducibility Standard Deviation	Repeatability Limit	Reproducibility Limit
K_{Ic} ($\text{MPa}\sqrt{\text{m}}$)	2219–T851 (353 MPa)	35.61	1.91	2.17	5.36	6.07
	Maraging 18Ni (1903 MPa)	59.06	2.14	2.65	5.98	7.41
	4340–500 F (1641 MPa)	50.38	2.12	2.87	5.95	8.04
	4340–800 F (1420 MPa)	87.83	2.21	3.14	6.19	8.80

TABLE 3 Precision Precision for A(T) Specimens (Nominal Crack Size-to-Specimen Width Ratio $a/W = 0.5$)

Parameter	Specimen Type	Average	Repeatability Standard Deviation	Reproducibility Standard Deviation	Repeatability Limit	Reproducibility Limit
K_{Ic} ($\text{MPa}\sqrt{\text{m}}$)	$X/W = 0$	102.3	4.69	7.16	13.13	20.05
	$X/W = 0.05$	101.6	2.33	4.81	6.53	13.47

measurement from three round-robin programs (9, 10, 11) as described below. Results for bend, compact, and arc-shaped specimen configurations were obtained for several aluminum alloys and high strength steels. The materials were chosen for their reproducible, uniform composition and microstructure. Thereby the contribution of material variability to the measurement of K_{Ic} was minimized.

11.3.1 An interlaboratory study (8) for the measurement of plane strain fracture toughness, K_{Ic} on metallic materials, using SE(B) specimens, was conducted among nine laboratories using four metallic materials (one aluminum alloy and three high-strength steels). 180 specimens were tested (5 per laboratory and material). Analyses were undertaken in accordance with Practice E691, see ASTM Research Report No. E08-1004⁵ and Table 1.

11.3.2 A second interlaboratory study (9) for the measurement of plane strain fracture toughness, K_{Ic} on metallic materials, using C(T) specimens, was conducted among nine laboratories using the same four metallic materials (one aluminum alloy and three high-strength steels). 216 specimens were tested (6 per laboratory and material). Analyses were undertaken in accordance with Practice E691, see ASTM Research Report No. E08-1005⁶ and Table 2.

11.3.3 A third interlaboratory study (10) for the measurement of plane strain fracture toughness, K_{Ic} , using arc-shaped A(T) specimens, with two different loading hole configurations ($X/W = 0$ and $X/W = 0.5$), was conducted among eight laboratories using one high strength steel (Ni-Cr-Mo-V vacuum-degassed steel, yield strength $\sigma_{YS} = 1324$ MPa). 48 specimens were tested (from 3 to 5 per laboratory). Analyses

were undertaken in accordance with Practice E691, see ASTM Research Report No.E08-1006⁷ and Table 3.

11.3.4 The terms repeatability limit and reproducibility limit are used as specified in Practice E177.

11.3.5 The results presented in Table 1, Table 2, and Table 3 shall not be transferred to materials or K_{Ic} levels other than those relevant to the specific interlaboratory studies(8, 9, 10).

11.4 Alternative side-grooved specimens were tested to determine within-laboratory limit and repeatability according to the conditions in Terminology E456. The testing was performed on aluminum alloy 7055–T7951 using C(T) specimens having a nominal dimensions $W=50.8$ (2.0 in.), $B =25.4$ mm (1.0 in.) $B_N = 20.3$ mm (0.80 in.) notch root angle = 45° and notch root radius = 0.5mm (0.02 in.). The results are given in Table 4 along with results obtained from plain-sided specimens from manufactured the same lot of material, tested at the same time, and under the same test conditions The repeatability standard deviation for this test series 0.22 $\text{MPa}\sqrt{\text{m}}$ (0.20 $\text{ksi}\sqrt{\text{in.}}$) for side-grooved specimens and 0.33 $\text{MPa}\sqrt{\text{m}}$ (0.30 $\text{ksi}\sqrt{\text{in.}}$) for the plane-sided specimens.

11.5 *Bias*—There is no accepted standard value for the plane-strain fracture toughness of any material. In the absence of such a true value, any statement concerning bias is not meaningful.

⁷ Supporting data have been filed at ASTM International Headquarters and may be obtained by requesting Research Report: RR:E08-1006.

TABLE 4 Repeatability Results for Side-Grooved and Plane-Sided C(T) Specimens 7055–T7951

Parameter	Specimen Type	No. of Specimens	Average	Repeatability Standard Deviation	Repeatability Limit
K_{Ic} ($\text{MPa}\sqrt{\text{m}}$)	Side-Grooved	11	26.9	0.22	0.49
	Plane-Sided	11	27.9	0.33	0.74

⁵ Supporting data have been filed at ASTM International Headquarters and may be obtained by requesting Research Report: RR:E08-1004.

⁶ Supporting data have been filed at ASTM International Headquarters and may be obtained by requesting Research Report: RR:E08-1005.

ANNEXES

(Mandatory Information)

A1. DOUBLE-CANTILEVER DISPLACEMENT GAGE

A1.1 The displacement gage consists of two cantilever beams and a spacer block clamped together with a single bolt and nut (Fig. 2). Electrical-resistance strain gages are adhesively bonded to the tension and compression surfaces of each beam, and are connected as a Wheatstone bridge incorporating a suitable balancing resistor. The beams are made of material with a high ratio of yield strength-to-elastic modulus. One such material is solution treated Ti-13V-11Cr-3Al titanium alloy. For material of different modulus, the spring constant of the assembly is correspondingly different, but other characteristics

are unaffected. Detailed dimensions for the beams and spacer block are given in Figs. A1.1 and A1.2. Those particular values provide a linear (working) range from 3.8 to 7.6 mm (0.15 to 0.30 in.) and a gage length of 5.1 to 6.4 mm (0.20 to 0.25 in.). The gage length can be adjusted by substituting a differently sized spacer block. The gage's required precision is stated as a maximum deviation of ± 0.003 mm (0.0001 in.) from a least-squares-best-fit straight line through its displacement calibration data (see 6.4.2). Additional details concerning design, construction and use of the gage are given in (13).

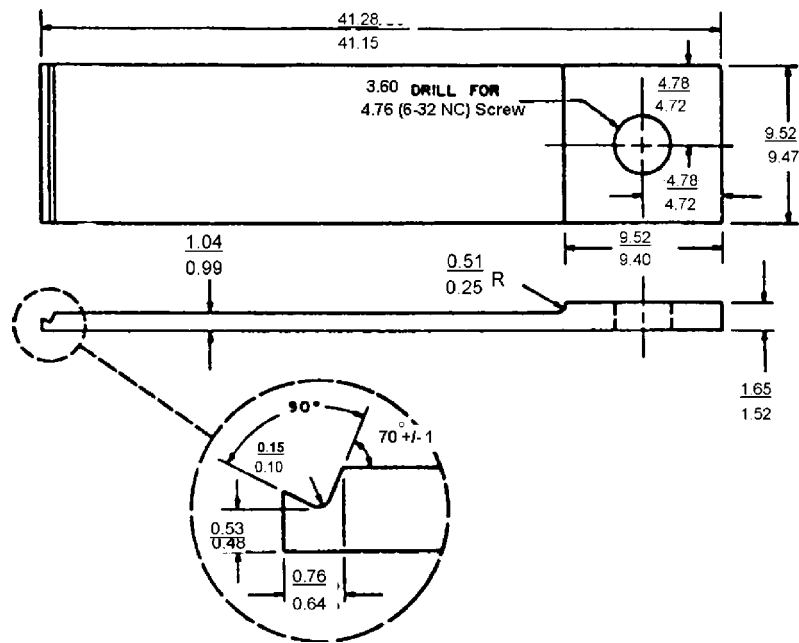

NOTE 1—Dimensions are in mm.

Inch-Pound Units Equivalents			
mm	in.	mm	in.
0.10	0.004	1.52	0.060
0.15	0.006	1.65	0.065
0.25	0.010	3.6	⁹ / ₆₄
0.48	0.019	4.72	0.186
0.51	0.020	4.78	0.188
0.53	0.021	9.40	0.370
0.64	0.025	9.47	0.373
0.76	0.030	9.52	0.375
0.99	0.039	41.15	1.620
1.04	0.041	41.28	1.625

FIG. A1.1 Beams for Double-Cantilever Displacement Gage

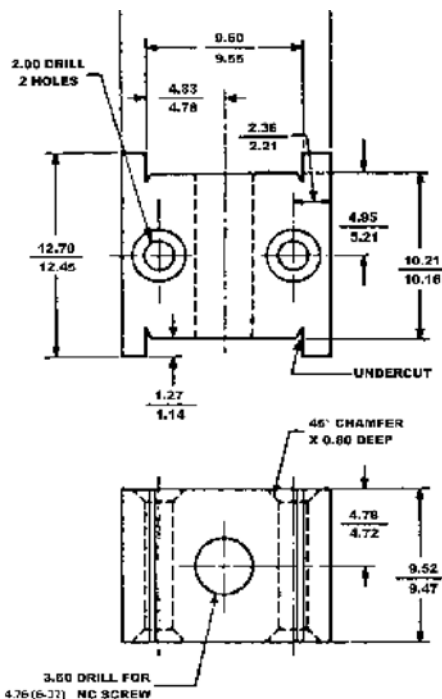

NOTE 1—2-mm diameter holes are for strain gage leads.

NOTE 2—Dimensions are in mm.

Inch-Pound Units Equivalents			
mm	in.	mm	in.
0.80	1/32	4.95	0.195
1.14	0.045	5.21	0.205
1.27	0.050	9.47	0.373
2.00	5/64	9.52	0.375
2.21	0.087	9.55	0.376
2.36	0.093	9.60	0.378
3.18	0.125	10.16	0.400
3.60	9/64	10.21	0.402
4.72	0.186	12.45	0.490
4.78	0.188	12.70	1/2
4.83	0.190	12.70	0.500

FIG. A1.2 Aluminum-Alloy Spacer Block for Double-Cantilever Displacement Gage

A2. TESTING FIXTURES

A2.1 Bend Specimen Loading Fixture

A2.1.1 The bend test is performed using fixtures designed to minimize friction effects by allowing the support rollers to rotate and translate slightly as the specimen is loaded, thereby achieving rolling contact. A design suitable for testing standard bend (SE(B)) and arc-shaped bend (A(B)) specimens is shown in Fig. A2.1. While free to roll and translate during test, the rollers are initially positioned against stops that set the span length and are held in place by low-tension springs (such as rubber bands).

A2.1.2 The bend fixture is aligned such that the line of action of the applied force passes midway between the support rollers to $\pm 1.0\%$ of the span, S , and is perpendicular to the roller axes to $\pm 2^\circ$ (14). The span is to be measured to $\pm 0.5\%$.

A2.2 Compact Specimen Loading Clevis

A2.2.1 A loading clevis suitable for testing standard compact (C(T)), arc-shaped tension (A(T)), and disk-shaped compact (DC(T)) specimens is shown in Fig. A2.2. Both ends of the specimen are held in the clevis and loaded through pins in order to allow rotation of the specimen during testing. The clevis holes are provided with small flats on the loading surfaces to provide rolling contact, thereby minimizing friction effects (15).

A2.2.2 The size, proportions, and tolerances for the clevis shown in Fig. A2.2 are all scaled to specimens with $W/B = 2$ for $B \geq 13$ mm (0.5 in.), and $W/B = 4$ for $B \leq 13$ mm (0.5 in.). Clevis and pins made from 1930 MPa (280 ksi) yield strength maraging steel are suitable for testing specimens of the sizes

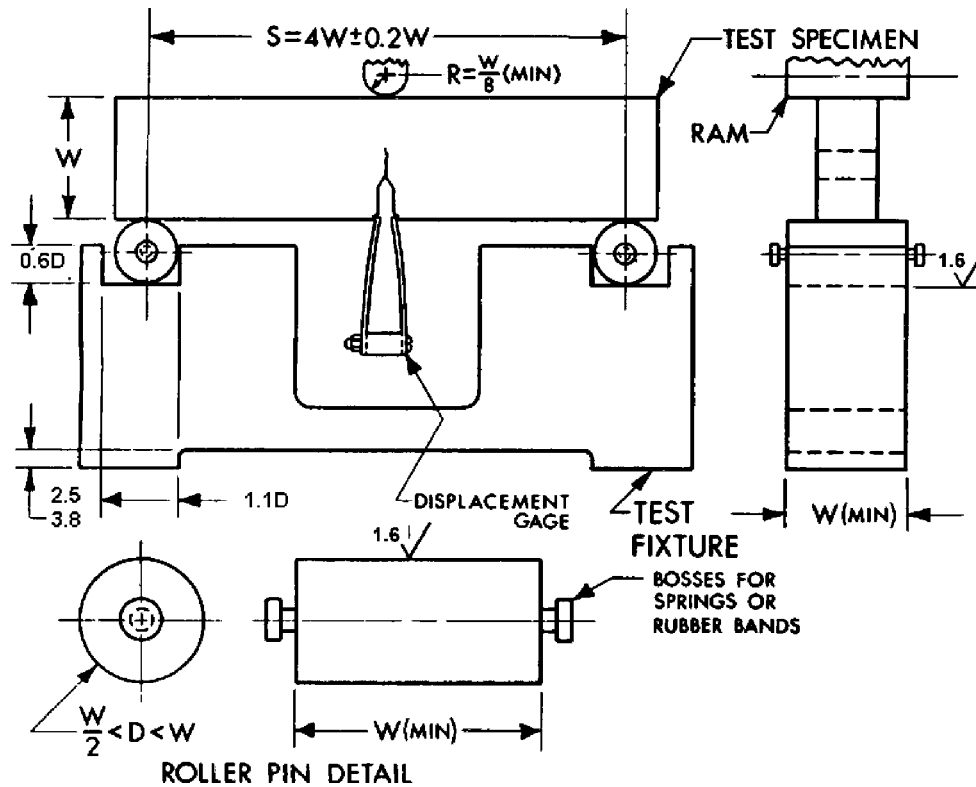

NOTE 1—Dimensions in mm, except surface finishes in μm .

NOTE 2—Support rollers and specimen contact surface of loading ram shall be parallel to each other within $0.002 W$.

NOTE 3— $2.54 \text{ mm} = 0.100 \text{ in.}$, $3.81 \text{ mm} = 0.150 \text{ in.}$, $1.6 \mu\text{-m} = 63 \mu\text{-in.}$

FIG. A2.1 Loading Fixture for Standard SE(B) (shown) and Arc-Shaped A(B) (not shown) Bend Specimens

and σ_{ys}/E ratios of 7.1.3. For lower-strength clevis material or substantially larger specimens at a given σ_{ys}/E ratio, larger clevises are required. As indicated in Fig. A2.2, the clevis corners may be trimmed sufficiently to accommodate seating of the displacement gage in specimens less than 9.53 mm (0.375 in.) thick.

A2.2.3 To minimize eccentricity in the load train, the loading rods shall be aligned to $\pm 0.8 \text{ mm}$ (0.03 in.) and the specimen centered in the clevis slot to $\pm 0.8 \text{ mm}$ (0.03 in.).

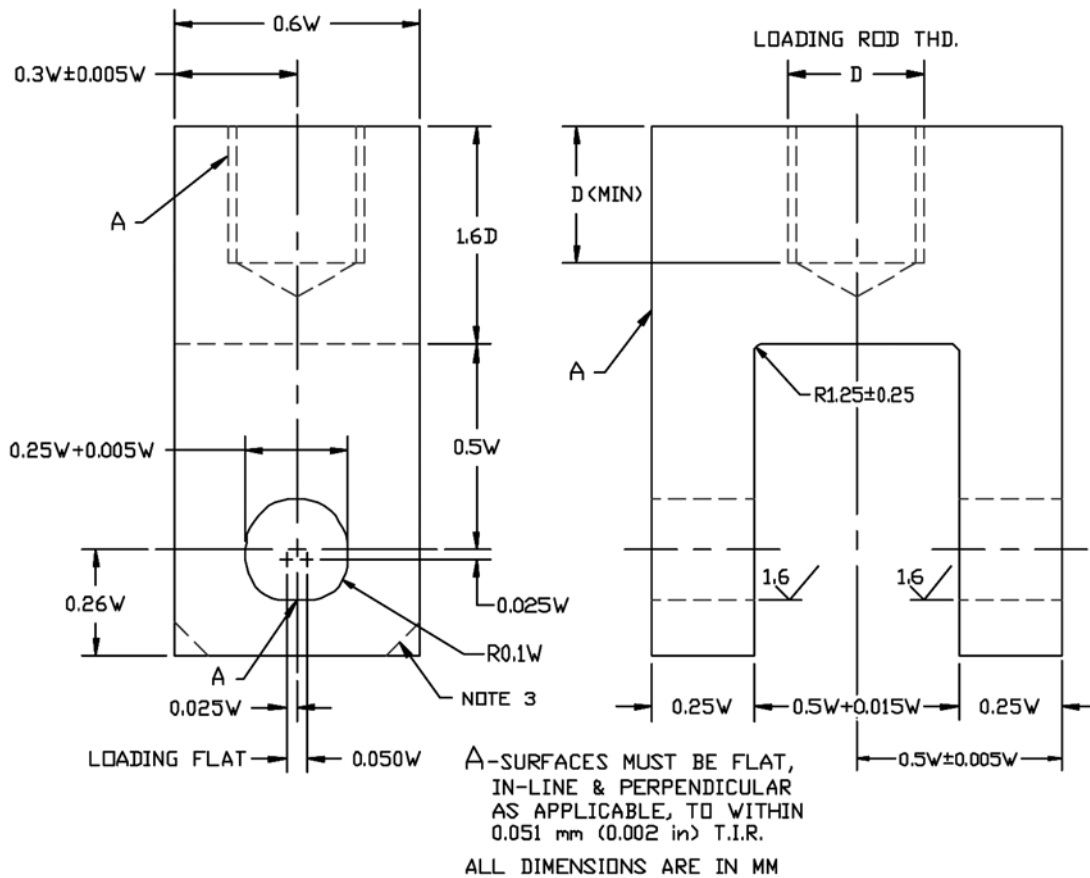

NOTE 1—Surface finishes in μm .

NOTE 2—Pin diameter = $0.24 W (+0.000 W/-0.005 W)$. For specimens with $\sigma_{ys} > 1379 \text{ MPa}$ (200 ksi), the holes in the specimen and in the clevis may be $0.30 W (+0.005 W/-0.000 W)$ and the pin diameter $0.288 W (+0.000 W/-0.005 W)$.

NOTE 3—Corners of the clevis may be removed if necessary to accommodate the clip gage.

NOTE 4— $1.6 \mu\text{m} = 63 \mu\text{in.}$, $3.2 \mu\text{m} = 125 \mu\text{in.}$

NOTE 5—Accumulated experience indicates that subtle deviation from the recommended configuration can lead to complications. For instance, undersized loading pins can lead to inelastic load transfer from clevis to specimen. Poorly machined flats can also cause difficulties.

FIG. A2.2 Loading Clevis for Compact C(T), Arc-Shaped A(T) and Disk-Shaped DC(T) Tension Specimens

A3. SPECIAL REQUIREMENTS FOR TESTING BEND SPECIMENS

A3.1 Specimen

A3.1.1 The standard bend specimen configuration is a single-edge-notched and fatigue precracked beam loaded in three-point bending. The support span, S , is nominally equal to four times the specimen width, W . The general proportions of the standard configuration are shown in Fig. A3.1.

A3.1.2 Alternative configurations may have $1 \leq W/B \leq 4$; however, these specimens shall also have a nominal support span equal to $4W$.

A3.2 Specimen Preparation

A3.2.1 Generally applicable specifications regarding specimen size, configuration and preparation are given in Section 7.

A3.2.2 In the interest of K -calibration accuracy, it is desirable to fatigue precrack bend specimens using the same loading fixture to be used in subsequent testing.

A3.2.3 Bend specimens are occasionally precracked in cantilever bending, especially for reversed force cycling (see A9.2.3.2). If the three-point bending K -calibration is used for cantilever bending, the cantilever bending moment for a given K value will be underestimated (7). The crack tip stress field in cantilever bending can be distorted by excessive clamping forces, thereby affecting fatigue crack planarity.

A3.3 Apparatus

A3.3.1 Bend Test Fixture—The loading fixture for bend testing is illustrated in Fig. A2.1 and discussed in A2.1. The

fixture is designed to minimize friction effects by allowing the rollers to rotate and translate slightly as the specimen is loaded, thus providing rolling contact.

A3.3.2 Displacement Gage—Details regarding displacement gage design, calibration, and use are given in 6.4. For the bend specimen, displacements are essentially independent of gage length up to $W/2$.

A3.4 Procedure

A3.4.1 Measurement—Specimen width (depth), W , is measured from the notched edge of the specimen to the opposite edge. Crack size a , is measured from the notched edge to the crack front.

A3.4.1.1 General requirements concerning specimen measurement are given in 8.2.

A3.4.2 Bend Specimen Testing—General principles concerning the loading fixture and its setup appear in A2.1.

A3.4.2.1 Locate the specimen with the crack tip midway between the rolls to within 1 % of the span, and square to the roll axes within 2°. The displacement gage is seated on the knife edges such as to maintain registry between knife edges and gage grooves. In the case of attachable knife edges, the gage is seated before the knife edge positioning screws are tightened.

A3.4.2.2 The specified rate of increase of the stress-intensity factor (see 8.3) ranges from 0.55 and 2.75 MPa $\sqrt{m/s}$ (30 and 150 ksi $\sqrt{in./min}$) and corresponds to a loading rate for a standard ($W/B = 2$) 25.4 mm (1 in.) thick specimen between 0.30 to 1.5 kN/s (4.0 and 20 klbf/min).

A3.4.2.3 Details concerning recording of the test record are given in 8.4.

A3.5 Calculations

A3.5.1 Interpretation of Test Record—General requirements and procedures for interpreting the test record are given in 9.1.

A3.5.2 Validity Requirements—Validity requirements in terms of limitation on P_{max}/P_Q and mandatory specimen size are given in 9.1.3 through 9.1.4.

A3.5.3 Calculation of K_Q —Bend specimen K_Q is calculated in SI or inch-pound units of Pa \sqrt{m} (psi $\sqrt{in.}$) as follows (see Note A3.2):

$$K_Q = \frac{P_Q S}{\sqrt{B B_N} W^{3/2}} \cdot f\left(\frac{a}{W}\right) \quad (\text{A3.1})$$

where:

$$f\left(\frac{a}{W}\right) = \quad (\text{A3.2})$$

$$3 \sqrt{\frac{a}{W}} \cdot \frac{1.99 - \frac{a}{W} - 1 - \frac{a}{W} \cdot 2.15 - 3.93 \frac{a}{W} + 2.7 \frac{a^2}{W^2}}{21 + 2 \frac{a}{W} - 1 - \frac{a}{W}^{3/2}}$$

for which:

P_Q = force as determined in 9.1.1, N (lbf),
 B = specimen thickness as determined in 8.2.1, m (in.),

B_N = specimen thickness between the roots of the side grooves, as determined in 8.2.1, m (in.),

S = span as determined in A3.4.2 (see also A2.1), m (in.),

W = specimen width (depth) as determined in A3.4.1, m (in.), and

a = crack size as determined in 8.2.3, m (in.).

NOTE A3.1—Example: for $a/W = 0.500$, $f(a/W) = 2.66$.

NOTE A3.2—This expression for a/W is considered to be accurate within 1 % over the range $0.2 \leq a/W \leq 1$ for $S/W = 4$ (16).

A3.5.4 Calculation of Crack Mouth Opening Compliance Using Crack Size Measurements—Bend specimen crack mouth opening compliance, V_m/P , is calculated in units of m/N (in./lb) as follows (see Note A3.4):

$$\frac{V_m}{P} = \frac{S}{E' B_e W} \cdot q\left(\frac{a}{W}\right) \quad (\text{A3.3})$$

where:

$$q\left(\frac{a}{W}\right) = \quad (\text{A3.4})$$

$$6\left(\frac{a}{W}\right) \left[0.76 - 2.28 \frac{a}{W} + 3.87 \left(\frac{a}{W}\right)^2 - 2.04 \left(\frac{a}{W}\right)^3 + 0.66 \left(1 - \frac{a}{W}\right)^2 \right]$$

for which:

E' = elastic constraint modulus (E for plane stress; $E/(1 - \nu^2)$ for plane strain), Pa (psi),

ν = Poisson's Ratio,

$B_e = B - (B - B_N)^2/B$, and

S , B , B_N , W , and a are defined in A3.5.3.

NOTE A3.3—Example: for $a/W = 0.500$, $q(a/W) = 8.92$.

NOTE A3.4—This expression is considered to be accurate within 1.0 % over the entire range $0 \leq a/W \leq 1$ for $S/W = 4$ (17). It is valid only for crack mouth opening displacement measured at the location of the integral knife edges shown in Fig. 3. Attachable knife edges must be reversed or inset to effect the same measurement points.

A3.5.5 Calculation of Crack Size Using Crack Mouth Opening Compliance Measurements—Bend specimen normalized crack size is calculated as follows (see Note A3.5):

$$\frac{a}{W} = \quad (\text{A3.5})$$

$$1.000 - 3.950 \cdot U + 2.982 \cdot U^2 - 3.214 \cdot U^3 + 51.516 \cdot U^4 - 113.031 \cdot U^5$$

where:

$$U = \frac{1}{1 + \sqrt{\left(\frac{E' B_e V_m}{P}\right) \left(\frac{4W}{S}\right)}} \quad (\text{A3.6})$$

for which:

V_m = crack mouth opening displacement, m (in.),

P = applied force, N (lbf), and

$B_e = B - (B - B_N)^2/B$, and

E' is defined in A3.5.4 and S , B , B_N , W and a are defined in A3.5.3.

NOTE A3.5—This expression fits the equation in A3.5.4 within 0.05 % of W in the range $0.3 \leq a/W \leq 0.9$ for $S/W = 4$ (18). It is valid only for crack mouth opening displacement measured at the location of the integral knife edges shown in Fig. 3. Attachable knife edges must be reversed or inset to effect the same measurement points.

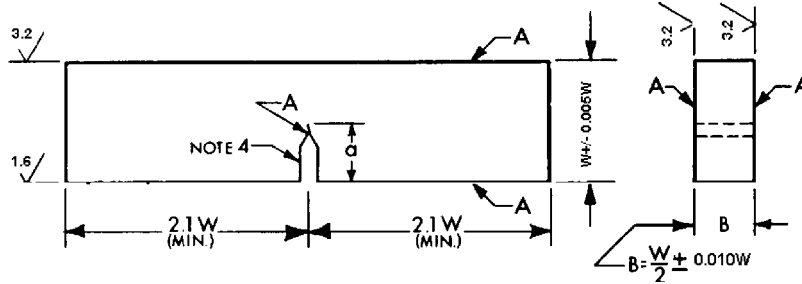

- NOTE 1—Surface finishes in μm .
- NOTE 2—A surfaces shall be perpendicular and parallel as applicable within $0.001 W$ TIR.
- NOTE 3—Crack starter notch shall be perpendicular to specimen surfaces within 2° .
- NOTE 4—Integral or attachable knife edges for clip gage attachment may be used (see Figs. 3 and 4)
- NOTE 5—For starter notch and fatigue crack configuration see Fig. 5.
- NOTE 6— $1.6 \mu\text{m} = 63 \mu\text{in.}$, $3.2 \mu\text{m} = 125 \mu\text{in.}$

FIG. A3.1 Bend SE(B) Specimen—Standard Proportions and Tolerances

A4. SPECIAL REQUIREMENTS FOR TESTING COMPACT SPECIMENS

A4.1 Specimen

A4.1.1 The standard compact specimen configuration is a single-edge-notched and fatigue precracked plate loaded in tension. The general proportions of the standard configuration are shown in Fig. A4.1.

A4.1.2 Alternative configurations may have $2 \leq W/B \leq 4$, but with other proportions unchanged.

A4.2 Specimen Preparation

A4.2.1 Generally applicable specifications regarding specimen size, configuration and preparation are given in Section 7.

A4.3 Apparatus

A4.3.1 *Tension Testing Clevis*—A loading clevis suitable for testing compact specimens is shown in Fig. A2.2 and discussed in A2.2. The clevis is designed to minimize friction effects by providing for rolling contact of the loading pins and rotation of the specimen during specimen loading.

A4.3.2 *Displacement Gage*—Details regarding displacement gage design, calibration, and use are given in 6.4. For the compact specimen, displacements are essentially independent of gage length up to $1.2W$.

A4.4 Procedure

A4.4.1 *Measurement*—Specimen width, W , and crack size, a , are measured from the plane of the centerline of the loading holes. The notched edge may be used as a convenient reference line, taking into account (that is, subtracting) the distance from the centerline of the holes to the notched edge to arrive at W and a .

A4.4.1.1 General requirements concerning specimen measurement are given in 8.2.

A4.4.2 *Compact Specimen Testing*—General principles concerning the loading clevis and its setup appear in A2.2. When assembling the loading train (clevises and their attachments to the tensile machine), care shall be taken to minimize eccentricity of loading due to misalignments external to the clevises.

A4.4.2.1 The displacement gage is seated on the knife edges such as to maintain registry between knife edges and gage grooves. In the case of attachable knife edges, the gage is seated before the knife edge positioning screws are tightened.

A4.4.2.2 The specified rate of increase of the stress-intensity factor is within the range 0.55 and $2.75 \text{ MPa}\sqrt{\text{m/s}}$ (30 and $150 \text{ ksi}\sqrt{\text{in./min}}$) corresponding to a loading rate for a standard ($W/B = 2$) 25 mm (1.0 in.) thick specimen between 0.33 and 1.67 kN/s (4.5 to 22.5 klbf/min).

A4.4.2.3 Details concerning recording of the test record are given in 8.4.

A4.5 Calculations

A4.5.1 General requirements and procedures for interpreting the test record are given in 9.1.

A4.5.2 *Validity Requirements*—Validity requirements in terms of limitation on P_{max}/P_Q and mandatory specimen size are given in 9.1.3 through 9.1.4.

A4.5.3 *Calculation of K_Q* —Compact specimen K_Q is calculated in SI or inch-pound units of $\text{Pa}\sqrt{\text{m}}$ ($\text{psi}\sqrt{\text{in.}}$) as follows (see Note A4.2):

$$K_Q = \frac{P_Q}{\sqrt{B}B_N\sqrt{W}} \cdot f\left(\frac{a}{W}\right) \quad (\text{A4.1})$$

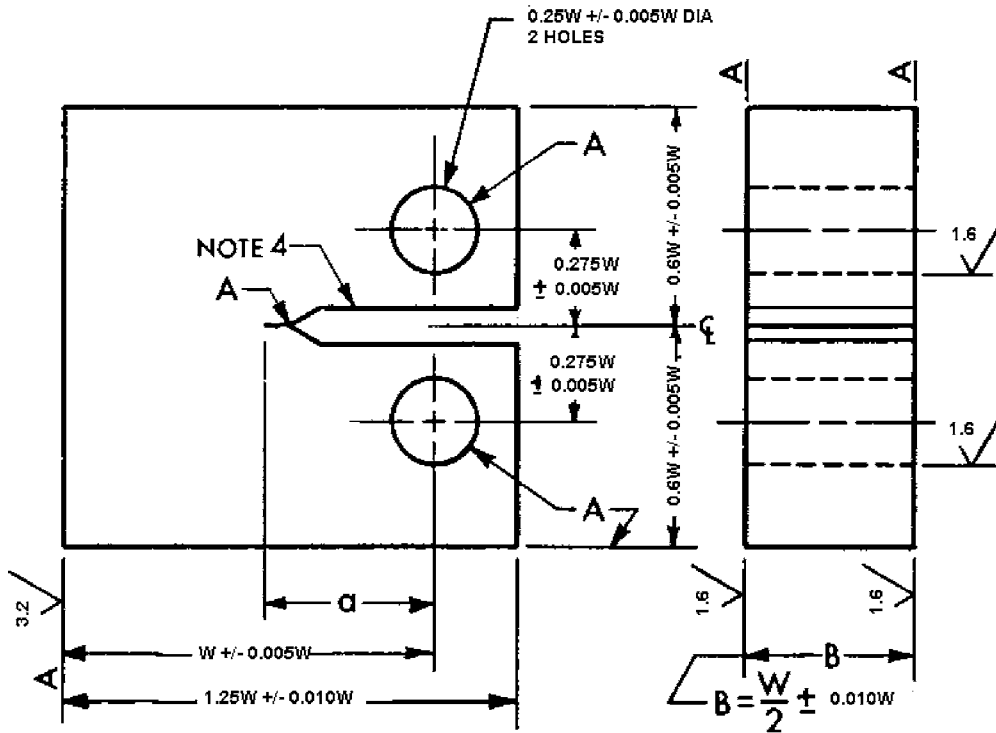

NOTE 1—Surface finishes in μm .

NOTE 2—A surfaces shall be perpendicular and parallel to within $0.002 W$ TIR.

NOTE 3—The intersection of the crack starter notch tips with the two specimen surfaces shall be equally distant from the top and bottom edges of the specimen within $0.005 W$.

NOTE 4—Integral or attachable knife edges for clip gage attachment to the crack mouth may be used (see Figs. 3 and 4).

NOTE 5—For starter notch and fatigue crack configuration see Fig. 5.

NOTE 6— $1.6 \mu\text{m} = 63 \mu\text{in.}$, $3.2 \mu\text{m} = 125 \mu\text{in.}$

FIG. A4.1 Compact C(T) Specimen—Standard Proportions and Tolerances

where:

$$f\left(\frac{a}{W}\right) = \quad (A4.2)$$

$$\frac{\left(2 + \frac{a}{W}\right) \left[0.886 + 4.64\frac{a}{W} - 13.32\left(\frac{a}{W}\right)^2 + 14.72\left(\frac{a}{W}\right)^3 - 5.6\left(\frac{a}{W}\right)^4\right]}{\left(1 - \frac{a}{W}\right)^{3/2}}$$

for which:

- P_O = force as determined in 9.1.1, N (lbf),
- B = specimen thickness as determined in 8.2.1, m (in.),
- B_N = specimen thickness between the roots of the side grooves, as determined in 8.2.1, m (in.),
- W = specimen width (depth) as determined in A3.4.1, m (in.), and
- a = crack size as determined in 8.2.3 and A4.4.1, m (in.).

NOTE A4.1—Example: for $a/W = 0.500$, $f(a/W) = 9.66$.

NOTE A4.2—This expression for a/W is considered to be accurate within 0.5 % over the range $0.2 \leq a/W \leq 1$ (19, 20).

A4.5.4 Calculation of Crack Mouth Opening Compliance Using Crack Size Measurements—Compact specimen crack mouth opening compliance, V_m/P , is calculated in units of m/N (in./lb) as follows (see Note A4.4):

$$\frac{V_m}{P} = \frac{1}{E' B_e} \cdot q\left(\frac{a}{W}\right) \quad (A4.3)$$

where:

$$q\left(\frac{a}{W}\right) = \quad (A4.4)$$

$$\frac{19.75}{\left(1 - \frac{a}{W}\right)^2} \left[0.5 + 0.192\frac{a}{W} + 1.385\left(\frac{a}{W}\right)^2 - 2.919\left(\frac{a}{W}\right)^3 + 1.842\left(\frac{a}{W}\right)^4\right]$$

for which:

- E' = elastic constraint modulus (E for plane stress, Pa (psi); $E/(1 - \nu^2)$ for plane strain, Pa (psi)),
- ν = Poisson's Ratio,
- $B_e = B - (B - B_N)^2/B$, and

B , B_N , W and a are defined in A4.5.3.

NOTE A4.3—Example: for $a/W = 0.500$, $q(a/W) = 54.71$.

NOTE A4.4—This expression is considered to be accurate to within 1.0 % for $a/W \geq 0.2$ (21). This expression is valid only for crack mouth opening displacement measured at the location of the integral knife edges shown in Fig. 3. Attachable knife edges must be reversed or inset to effect the same measurement points.

A4.5.5 Calculation of Crack Size Using Crack Mouth Opening Compliance Measurements—Compact specimen normalized crack size is calculated as follows (see Note A4.5):

$$\frac{a}{W} = \frac{1}{1 + \sqrt{\frac{E' B_e V_m}{P}}} \quad (A4.5)$$

P = applied force, N (lbf), and
 $B_e = B - (B - B_N)^2/B$, and

$$1.000 - 4.500 \cdot U + 13.157 \cdot U^2 - 172.551 \cdot U^3 + 879.944 \cdot U^4 - 1514.671 \cdot U^5$$

where:

$$U = \frac{1}{1 + \sqrt{\frac{E' B_e V_m}{P}}} \quad (A4.6)$$

for which:

V_m = crack mouth opening displacement, m (in.),

E' is defined in A4.5.4 and B , B_N , W and a are defined in A4.5.3.

NOTE A4.5—This expression fits the equation in A4.5.4 within 0.01 % of W for $0.2 \leq a/W \leq 0.8$ (21). It is valid only for crack mouth opening displacement measured at the location of the integral knife edges shown in Fig. 3. Attachable knife edges must be reversed or inset to effect the same measurement points.

A5. SPECIAL REQUIREMENTS FOR TESTING DISK-SHAPED COMPACT SPECIMENS

A5.1 Specimen

A5.1.1 The standard disk-shaped compact specimen configuration is a single-edge-notched and fatigue precracked disk segment loaded in tension (22). The general proportions of the standard configuration are shown in Fig. A5.1.

A5.1.2 Alternative configurations may have $2 \leq W/B \leq 4$, but with other proportions unchanged.

A5.2 Specimen Preparation

A5.2.1 Generally applicable specifications regarding specimen size, configuration and preparation are given in Section 7.

A5.3 Apparatus

A5.3.1 *Tension Testing Clevis*—A loading clevis suitable for testing disk-shaped compact specimens is shown in Fig. A2.2

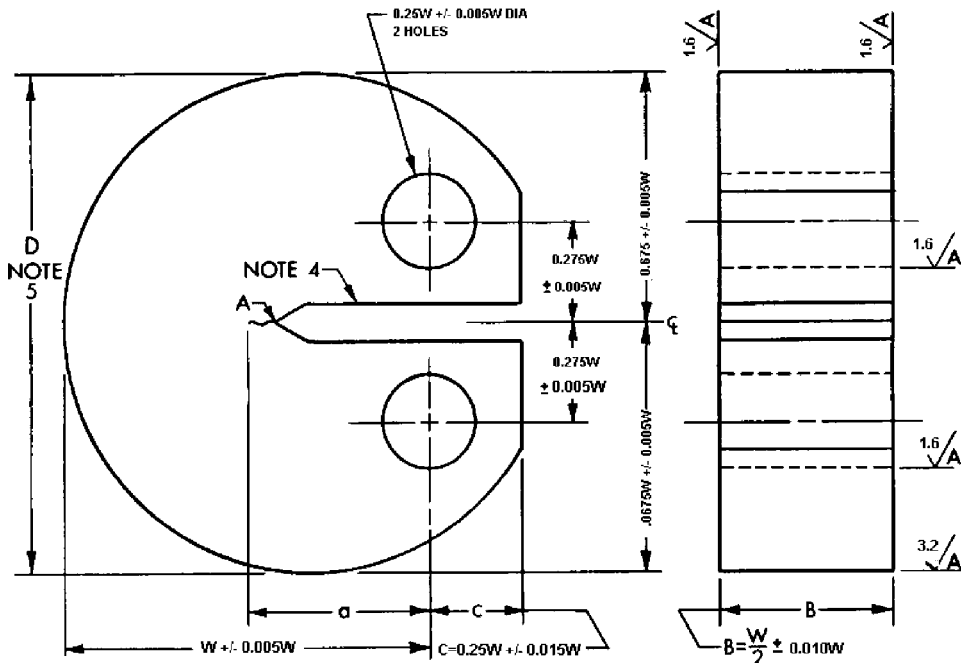

NOTE 1—Surface finishes in μm .

NOTE 2—A surfaces shall be perpendicular and parallel to within $0.002 W$ TIR.

NOTE 3—The intersection of the crack starter notch tips with the two specimen surfaces shall be equally distant from the top and bottom edges of the specimen within $0.005 W$.

NOTE 4—Integral or attachable knife edges for clip gage attachment to the crack mouth may be used (see Figs. 3 and 4).

NOTE 5—For starter notch and fatigue crack configuration see Fig. 5.

NOTE 6— $1.6 \mu\text{m} = 63 \mu\text{in}$, $3.2 \mu\text{m} = 125 \mu\text{in}$.

FIG. A5.1 Disk-Shaped Compact DC(T) Specimen—Standard Proportions and Tolerances

and discussed in [A2.2](#). The clevis is designed to minimize friction effects by providing for rolling contact of the loading pins and rotation of the specimen during specimen loading.

A5.3.2 Displacement Gage—Details regarding displacement gage design, calibration, and use are given in [6.4](#). For the disk-shaped compact specimen, displacements are essentially independent of gage length up to $0.55W$.

A5.4 Procedure

A5.4.1 Measurement—Analyses of this specimen assume it is machined from a circular blank and therefore measurements of circularity as well as width, W , and crack size, a , must be made.

A5.4.1.1 The specimen blank shall be checked for circularity before specimen machining. The radius shall be measured at eight equally spaced points around the circumference, and one of these points shall lie in the intended crack plane. The average of these readings is taken as the radius, r . If any measurement differs from r by more than 5.0 %, the blank is to be machined to the required circularity. Otherwise, $D = 2r = 1.35W$.

A5.4.1.2 Specimen width, W , and crack size, a , are measured from the plane of the centerline of the loading holes. The notched edge may be used as a convenient reference line taking into account (that is, subtracting) the distance from the centerline of the holes to the notched edge to arrive at W and a .

A5.4.1.3 General requirements concerning specimen measurement are given in [8.2](#).

A5.4.2 Disk-Shaped Compact Specimen Testing—General principles concerning the loading clevis and its setup appear in [A2.2](#). When assembling the loading train (clevises and their attachments to the tension machine), care shall be taken to minimize eccentricity of loading due to misalignments external to the clevises.

A5.4.2.1 The displacement gage is seated on the knife edges such as to maintain registry between knife edges and gage grooves. In the case of attachable knife edges, the gage is seated before the knife edge positioning screws are tightened.

A5.4.2.2 The specified rate of increase of the stress-intensity factor is within the range 0.55 and 2.75 MPa $\sqrt{m/s}$ (30 and 150 ksi $\sqrt{in./min}$) corresponding to a loading rate for a standard ($W/B = 2$) 25 mm (1.0 in.) thick specimen between 0.33 and 1.67 kN/s (4.5 to 22.5 klbf/min).

A5.4.2.3 Details concerning recording of the test record are given in [8.4](#).

A5.5 Calculations

A5.5.1 General requirements and procedures for interpreting the test record are given in [9.1](#).

A5.5.2 Validity Requirements—Validity requirements in terms of limitation on P_{max}/P_Q and mandatory specimen size requirements are given in [9.1.3](#) through [9.1.4](#).

A5.5.3 Calculation of K_Q —Disk-shaped compact specimen K_Q is calculated in SI or inch-pound units of Pa \sqrt{m} (psi $\sqrt{in.}$) as follows (see [Note A5.2](#)):

$$K_Q = \frac{P_Q}{B\sqrt{W}} \cdot f\left(\frac{a}{W}\right) \quad (\text{A5.1})$$

where:

$$f\left(\frac{a}{W}\right) = \quad (\text{A5.2})$$

$$\frac{\left(2 + \frac{a}{W}\right) \left[0.76 + 4.8 \frac{a}{W} - 11.58 \left(\frac{a}{W}\right)^2 + 11.43 \left(\frac{a}{W}\right)^3 - 4.08 \left(\frac{a}{W}\right)^4 \right]}{\left(1 - \frac{a}{W}\right)^{3/2}}$$

for which:

P_Q = force as determined in [9.1.1](#), N (lbf),

B = specimen thickness as determined in [8.2.1](#), m (in.),

W = specimen width (depth) as determined in [A5.4.1](#), m (in.), and

a = crack size as determined in [8.2.3](#) and [A5.4.1](#), m (in.).

NOTE A5.1—Example: for $a/W = 0.500$, $f(a/W) = 10.17$.

NOTE A5.2—This expression for a/W is considered to be accurate within 0.3 % over the range $0.2 \leq a/W \leq 1$ ([23](#)).

A5.5.4 Calculation of Crack Mouth Opening Compliance Using Crack Size Measurements—Disk-shaped compact specimen crack mouth opening compliance, V_m/P , is calculated in units of m/N (in./lb) as follows (see [Note A5.4](#)):

$$\frac{V_m}{P} = \frac{1}{E' B} \cdot q\left(\frac{a}{W}\right) \quad (\text{A5.3})$$

where:

$$q\left(\frac{a}{W}\right) = \quad (\text{A5.4})$$

$$\frac{19.75}{\left(1 - \frac{a}{W}\right)^2} \left[0.469 - 0.056 \frac{a}{W} + 1.86 \left(\frac{a}{W}\right)^2 - 2.06 \left(\frac{a}{W}\right)^3 + 0.789 \left(\frac{a}{W}\right)^4 \right]$$

for which:

E' = elastic constraint modulus (E for plane stress, Pa (psi); $E/(1 - \nu^2)$ for plane strain, Pa (psi),

ν = Poisson's Ratio, and

B , W and a are defined in [A5.5.3](#).

NOTE A5.3—Example: for $a/W = 0.500$, $q(a/W) = 55.1$.

NOTE A5.4—This expression is considered to be accurate to within 1.0 % for $a/W \geq 0.2$ ([21](#)). This expression is valid only for crack mouth

TABLE A5.1 Results of K_{Ic} Tests on Disk-Shaped Compact DC(T), Compact C(T), Arc-Shaped A(T) Tension Specimens

	Laboratory 1 Ni-Cr-Mo Steel $\sigma_{ys} = 1324$ MPa (192 ksi)		Laboratory 2 Ni-Cr-Mo Steel $\sigma_{ys} = 1289$ MPa (187 ksi)	
	Disk-Shaped Compact, DC(T)	Arc-Shaped Tension, A(T)	Disk-Shaped Compact, DC(T)	Standard Compact, A(T)
Mean, \bar{X}	109.4 (99.5)	109.2 (99.4)	114.7 (104.4)	116.4 (105.9)
Standard Deviation, S	4.38 (3.99)	3.76 (3.42)	1.86 (1.69)	3.56 (3.24)

NOTE 1—Units of mean and standard deviation are MPa \sqrt{m} (ksi $\sqrt{in.}$).

opening displacement measured at the location of the integral knife edges shown in Fig. 3. Attachable knife edges must be reversed or inset to effect the same measurement points.

A5.5.5 Calculation of Crack Size Using Crack Mouth Opening Compliance Measurements—Disk-shaped compact specimen normalized crack size is calculated as follows (see Note A5.5):

$$\frac{a}{W} = \quad (\text{A5.5})$$

$$1.000 - 4.459 \cdot U + 2.066 \cdot U^2 - 13.041 \cdot U^3 + 167.627 \cdot U^4 - 481.4 \cdot U^5$$

where:

$$U = \frac{1}{1 + \sqrt{\frac{E' BV_m}{P}}} \quad (\text{A5.6})$$

for which:

- V_m = crack mouth opening displacement, m (in.),
- P = applied force, N (lbf), and

E' is defined in A5.5.4 and B , W and a are defined in A5.5.3.

NOTE A5.5—This expression fits the equation in A5.5.4 within 0.01 % of W for $0.2 \leq a/W \leq 0.8$ (21). This expression is valid only for crack mouth opening displacement measured at the location of the integral knife edges shown in Fig. 3. Attachable knife edges must be reversed or inset to effect the same measurement points.

A5.6 Precision and Bias (see also Section 11)

A5.6.1 There has been no round-robin test program for the disk-shaped compact specimen. However, the results of two testing programs (22) designed to compare the results of the disk-shaped compact DC(T) specimen with those of the compact C(T) and arc-shaped tension A(T) specimens are summarized in Table A5.1. Based on the results in Table A5.1 and the geometric similarity of the specimens, there is no reason to suspect that the precision for the disk-shaped compact specimen would differ from that for the standard compact specimen. The arc-tension specimen has been shown (10) to have essentially the same grand mean and standard deviation as the standard compact specimen.

A6. SPECIAL REQUIREMENTS FOR TESTING ARC-SHAPED TENSION SPECIMENS

A6.1 Specimen

A6.1.1 The standard arc-shaped tension specimen configuration is a single-edge-notched and fatigue precracked ring segment loaded in tension. The general proportions of (two variants of) the standard configuration are shown in Fig. A6.1. The value of the radius ratio r_1/r_2 is unspecified, so specimens may be taken from any cylindrical geometry. It should be noted, however, that specimens with $r_1/r_2 = 0$ (that is, from a solid cylinder) do not make efficient use of test material, because W for the arc-shaped tension specimen applies to hollow cylinders. The disk-shaped specimen shall be used for tests of solid cylinders (see Annex A5).

A6.1.2 The arc-shaped tension specimen measures toughness only for a crack whose normal is circumferential and propagation direction is radial, designated C-R (see 3.1.4). For other crack plane orientations and propagation directions the bend (Annex A3) or compact (Annex A4) specimen are to be used.

A6.1.3 The specimen depicted in Fig. A6.1(a) with $X/W = 0.5$ represents a half-ring segment. The specimen with $X/W = 0$ (Fig. A6.1(b)) is the smallest specimen of this configuration that can be cut from a ring.

A6.1.4 Alternative configurations may have $2 \leq W/B \leq 4$, but with other proportions unchanged. The use of alternative specimen proportions is advantageous when a specimen can be extracted from a ring segments without machining the inner and outer radii; that is, with no change in W .

A6.2 Specimen Preparation

A6.2.1 Generally applicable specifications regarding specimen size, configuration and preparation are given in Section 7.

A6.3 Apparatus

A6.3.1 *Tension Testing Clevis*—A loading clevis suitable for testing arc-shaped tension specimens is shown in Fig. A2.2 and discussed in A2.2. The clevis is designed to minimize friction effects by providing for rolling contact of the loading pins and rotation of the specimen during specimen loading.

A6.3.2 *Displacement Gage*—Details regarding displacement gage design, calibration, and use are given in 6.4. For the arc-shaped tension specimen, displacements are essentially independent of gage length up to $W/2$.

A6.3.2.1 An alternative means for measuring displacement is permitted for the specimen with $X/W = 0.5$. Conical center-punch-type indentations are provided on the inner surface of the specimen at mid-thickness and in the plane of the centerline of the loading holes as shown in Fig. A6.1(a). Load-point displacement is measured at these points using a displacement gage fitted with points and meeting the requirements of 6.4.

A6.4 Procedure

A6.4.1 *Measurement*—Before testing, $(r_2 - r_1)$ is measured to the nearest 0.03 mm (0.001 in.) or to 0.1 %, whichever is greater, at mid-thickness positions on both sides of, and immediately adjacent to, the crack starter notch mouth. The average of these two readings is taken as W . Measurement of $(r_2 - r_1)$ is also made at four additional positions, two as close as possible to the loading holes and two at approximately one-half the circumferential distance between the loading holes and the crack plane. If any of these four measurements differ from W by more than 10 %, the specimen shall be discarded or reworked. The distance between the loading-hole centers and

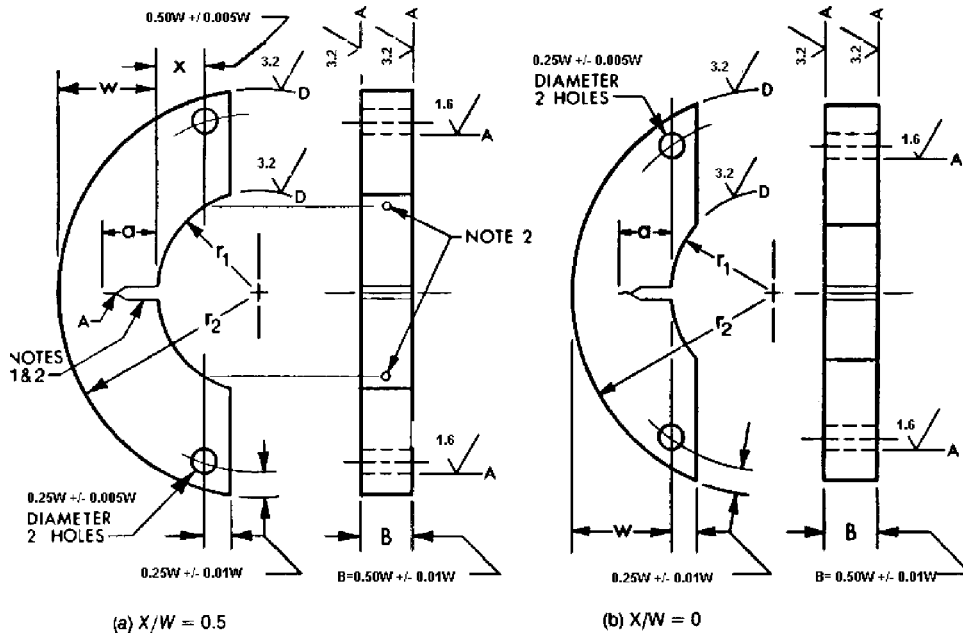

NOTE 1—Surface finishes in μm .

NOTE 2—For starter notch and fatigue crack configurations see Fig. 5.

NOTE 3—Alternative displacement gage reference points (see A6.4.1.1 for calculation of (a)).

NOTE 4—Axis of holes to be tangent to inner radius within 0.005 W.

NOTE 5—A surfaces to be perpendicular parallel as applicable within 0.002 W TIR. D surfaces to be perpendicular or parallel as applicable to A surfaces within 0.02 W TIR (see A6.4.1).

NOTE 6—1.6 μm = 63 μin , 3.2 μm = 125 μin .

FIG. A6.1 Arc-Shaped Tension A(T) Specimen Designs—Standard Proportions and Tolerances

the outside surface of the specimen at the notch plane is measured to the nearest 0.03 mm (0.001 in.) or to 0.1 %, whichever is greater. This measurement is made on both sides of the specimen by referencing the loading holes. Specimen width W is subtracted from the average of these two measurements and the difference recorded as the quantity X. The distance g between the crack mouth opening displacement measurement reference points is measured to within 5.0 %. [It should be recognized that g may be equal to the crack slot width, N, (for example, g = 6.4 mm (0.25 in.) in Fig. 3) or larger than N if machined knife edges are used.] The outer radius r₂ is measured, if possible, to within 5.0 %. If not possible, then an average value of r₂ is calculated (see Note A6.1) from the measured (within 5.0 %) length, L, of the chord of the outer surface, which chord passes through the loading hole centers (see Fig. A6.2), using the following relationship:

$$r_2 = \frac{L^2}{8(W+X)} + \frac{W+X}{2} \quad (\text{A6.1})$$

then:

$$\frac{r_1}{r_2} = 1 - \frac{W}{r_2} \quad (\text{A6.2})$$

NOTE A6.1—A10 % variation in the ratio r₁/r₂ will affect the value of stress-intensity factor by 1.0 % or less, providing that the relative crack size a/W is not less than 0.3. This, however, is based on the assumption that specimens are cut from stock of uniform, axisymmetric cross section. If inspection shows that the stock deviates from axisymmetry by more than 10 %, it should be reworked to within this tolerance.

A6.4.1.1 Post-test crack size measurement (in accordance with 8.2.3) involves a special procedure due to the specimen's

curvature. A size measurement, m, is made from a reference point on the curved inner surface, adjacent to the crack mouth, to a point on the crack front. That size is greater than the corresponding distance from the virtual point of intersection between the crack plane and the inside circumference of the specimen (see Fig. A6.2). Error, e, is computed from the following expression:

$$e = r_1 - \sqrt{r_1^2 - \frac{g^2}{4}} \quad (\text{A6.3})$$

where g is the distance between the crack mouth opening displacement measurement reference points. If the relative error e/m < 0.01, then m is taken as the crack size; otherwise e is subtracted from m and the result recorded as the crack size.

A6.4.2 Arc-Shaped Tension Specimen Testing—General principles concerning the loading clevis and its setup appear in A2.2. When assembling the load train (clevises and their attachments to the tension machine), care shall be taken to minimize eccentricity of loading due to misalignments external to the clevises.

A6.4.2.1 The displacement gage is seated on the knife edges such as to maintain registry between knife edges and gage grooves. In the case of attachable knife edges, the gage is seated before the knife edge positioning screws are tightened.

A6.4.2.2 The specified rate of increase of the stress-intensity factor is within the range 0.55 and 2.75 MPa $\sqrt{\text{m/s}}$ (30 and 150 ksi $\sqrt{\text{in./min}}$) corresponding to a loading rate between 0.21 and 1.04 kN/s (2.8 to 14.0 klbf/min) for a standard (W/B = 2) 25 mm (1.0 in.) thick specimen with X/W = 0.5, and

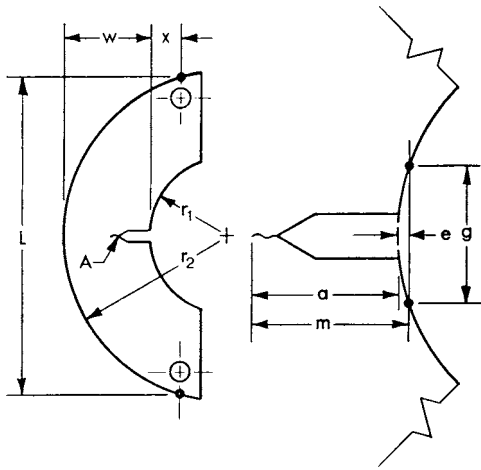

FIG. A6.2 Measurement of Outer Radius (r_2) and Crack Size for the Arc-Shaped Tension A(T) Specimen (see A6.4.1)

between 0.33 and 1.67 kN/s (4.5 to 22.5 klbf/min) for a standard ($W/B = 2$) 1 in. thick specimen with $X/W = 0$.

A6.4.2.3 Details concerning recording of the test record are given in 8.4.

A6.5 Calculations

A6.5.1 Interpretation of Test Record—General requirements and procedures for interpreting the test record are given in 9.1.

A6.5.2 Validity Requirements—Validity requirements in terms of limitation on P_{max}/P_Q and mandatory specimen size are given in 9.1.3 through 9.1.4.

A6.5.3 Calculation of K_Q —Arc-shaped tension specimen K_Q is calculated in SI or inch-pound units of $\text{Pa}\sqrt{\text{m}}$ ($\text{psi}\sqrt{\text{in.}}$) as follows (see Note A6.3):

$$K_Q = \dots \quad (\text{A6.4})$$

$$\frac{P}{B\sqrt{W}} \left(3 \frac{X}{W} + 1.9 + 1.1 \frac{a}{W} \right) \left[1 + 0.25 \left(1 - \frac{a}{W} \right)^2 \left(1 - \frac{r_1}{r_2} \right) \right] \cdot f \left(\frac{a}{W} \right)$$

where:

$$f \left(\frac{a}{W} \right) = \frac{\sqrt{\frac{a}{W}}}{\left(1 - \frac{a}{W} \right)^{3/2}} \left[3.74 - 6.30 \frac{a}{W} + 6.32 \left(\frac{a}{W} \right)^2 - 2.43 \left(\frac{a}{W} \right)^3 \right] \quad (\text{A6.5})$$

for which:

- P_Q = force as determined in 9.1.1, N (lbf),
- B = specimen thickness as determined in 8.2.1, m (in.),
- X = loading hole offset as determined in A6.4.1, m (in.),
- W = specimen width (depth) as determined in A6.4.1, m (in.),
- a = crack size as determined in 8.2.3 and A6.4.1.1, m (in.), and
- r_1/r_2 = ratio of inner-to-outer radii as determined in A6.4.1.

NOTE A6.2—Example: for $a/W = 0.500$, $f(a/W) = 3.73$.

NOTE A6.3—The accuracy of this expression for a/W for all values of r_1/r_2 is considered to be as follows: (1) within 1.0 % for $0.45 \leq a/W \leq 0.55$ and X/W of 0 or 0.5, (2) within 1.5 % for $0.2 \leq a/W \leq 1$ and X/W of 0 or 0.5, and (3) within 3.0 % for $0.2 \leq a/W \leq 1$ and $0 \leq X/W \leq 1$ (24).

A6.5.4 Calculation of Crack Mouth Opening Compliance Using Crack Size Measurements—Arc-shaped tension specimen crack mouth opening compliance, V_m/P , is calculated in units of m/N (in./lb) as follows (see Note A6.5):

for the specimen with $X/W = 0$:

$$\frac{V_m}{P} = \frac{P_1 \left(\frac{a}{W} \right)}{E' B} \cdot \left[0.43 \left(1 - \frac{r_1}{r_2} \right) + q_1 \left(\frac{a}{W} \right) \right] \quad (\text{A6.6})$$

where:

$$P_1 \left(\frac{a}{W} \right) = \frac{1 + \frac{a}{W}}{\left(1 - \frac{a}{W} \right)^2} \quad (\text{A6.7})$$

and:

$$q_1 \left(\frac{a}{W} \right) = 0.542 + 13.137 \frac{a}{W} - 12.316 \left(\frac{a}{W} \right)^2 + 6.576 \left(\frac{a}{W} \right)^3 \quad (\text{A6.8})$$

or, for the specimen with $X/W = 0.5$:

$$\frac{V_m}{P} = \frac{P_2 \left(\frac{a}{W} \right)}{E' B} \cdot \left[0.45 \left(1 - \frac{r_1}{r_2} \right) + q_2 \left(\frac{a}{W} \right) \right] \quad (\text{A6.9})$$

where:

$$P_2 \left(\frac{a}{W} \right) = \frac{2 + \frac{a}{W}}{\left(1 - \frac{a}{W} \right)^2} \quad (\text{A6.10})$$

and:

$$q_2 \left(\frac{a}{W} \right) = 0.399 + 12.63 \frac{a}{W} - 9.838 \left(\frac{a}{W} \right)^2 + 4.66 \left(\frac{a}{W} \right)^3 \quad (\text{A6.11})$$

for which:

- E' = elastic constraint modulus (E for plane stress, Pa (psi); $E/(1 - \nu^2)$ for plane strain, Pa (psi)),
- ν = Poisson's Ratio, and

$X, B, W, a,$ and (r_1/r_2) are defined in A6.5.3.

NOTE A6.4—Example: for $a/W = 0.500$, $p_1(a/W) = 6.00$, $q_1(a/W) = 4.85$, $p_2(a/W) = 10.00$, and $q_2(a/W) = 4.84$.

NOTE A6.5—These expressions are considered to be accurate within 1.4 % ($X/W = 0$) or 1.6 % ($X/W = 0.5$) for $0.2 \leq a/W \leq 0.8$ and $(r_1/r_2) \geq 0.4$ (21). These expressions are valid only for crack mouth opening displacement measured at the location of integral knife edges comparable to that shown in Fig. 3. Attachable knife edges must be reversed or inset to effect the same measurement points.

A6.5.5 Calculation of Crack Size Using Crack Mouth Opening Compliance Measurements—Arc-shaped tension specimen normalized crack size is calculated as follows (see Note A6.6):

for the specimen with $X/W = 0$:

$$\frac{a}{W} = \dots \quad (\text{A6.12})$$

$$0.989 - 3.463 \cdot U - 0.171 \cdot U^2 + 24.354 \cdot U^3 - 72.805 \cdot U^4 + 84.375 \cdot U^5$$

where:

$$U = \frac{1}{1 + \sqrt{\frac{E' BV_m}{P} \left[1 + 0.101 \left(1 - \frac{r_1}{r_2} \right) \right]}} \quad (\text{A6.13})$$

or, for the specimen with $X/W = 0.5$:

$$\frac{a}{W} = \quad (\text{A6.14})$$

$$0.986 - 4.082 \cdot U - 5.065 \cdot U^2 + 86.819 \cdot U^3 - 313.338 \cdot U^4 + 429.101 \cdot U^5$$

where:

$$U = \frac{1}{1 + \sqrt{\frac{E' BV_m}{P} \left[1 + 0.108 \left(1 - \frac{r_1}{r_2} \right) \right]}} \quad (\text{A6.15})$$

for which:

V_m = crack mouth opening displacement, m (in.),
 P = applied force, N (lbf), and

E' is defined in A6.5.4 and B , W , a and (r_1/r_2) are defined in A6.5.3.

NOTE A6.6—This expression fits the equations in A6.5.4 within $0.003W$ for $0.2 \leq a/W \leq 0.8$, $(r_1/r_2) \geq 0.4$, and $X/W = 0$ or 0.5 (20). This expression is valid only for crack mouth opening displacement measured at the location of the integral knife edges comparable to that shown in Fig. 3. Attachable knife edges must be reversed or inset to effect the same measurement points.

A7. SPECIAL REQUIREMENTS FOR TESTING ARC-SHAPED BEND SPECIMENS

A7.1 Specimen

A7.1.1 The standard arc-shaped bend specimen configuration (25) is a single-edge-notched and fatigue precracked ring segment loaded in bending. The general proportions of the standard configuration are shown in Fig. A7.1. The value of the radius ratio r_1/r_2 is limited to the range 0.6 to 1.0 when the span-to-width ratio S/W is 4, and from 0.4 to 1.0 when S/W is 3. For cylinders with radius ratios less than these limits, the arc-shaped tension-loaded specimen or the disk-shaped specimen shall be used.

A7.1.2 The arc-shaped bend specimen measures toughness only for a crack whose normal is circumferential and propa-

gation direction is radial, designated C-R (see 3.1.4). For other crack plane orientations and propagation directions the bend (Annex A3) or compact (Annex A4) specimen are to be used.

A7.1.3 Alternative configurations may have $2 \leq W/B \leq 4$, but with other proportions unchanged. The use of alternative specimen proportions is advantageous when a specimen can be extracted from a ring segment without machining the inner and outer radii.

A7.2 Specimen Preparation

A7.2.1 Generally applicable specifications regarding specimen size, configuration and preparation are given in Section 7.

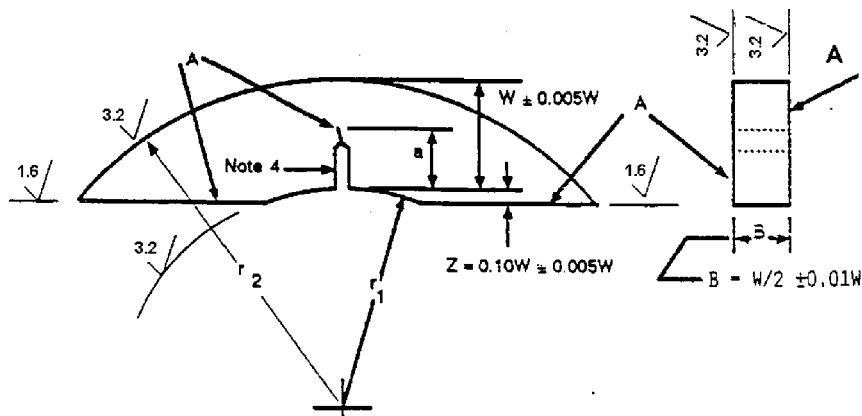

NOTE 1—Surface finishes in μm .

NOTE 2—A surfaces shall be perpendicular and parallel as applicable within $0.0001 W$ TIR.

NOTE 3—Crack starter notch shall be perpendicular to specimen surfaces within $\pm 2^\circ$

NOTE 4—Integral or attachable knife edges for clip gage attachment (see Figs. 3 and 4) shall be provided for displacement gage attachment.

NOTE 5—For starter notch and fatigue crack configuration, see Fig. 5.

NOTE 6— $1.6 \mu\text{m} = 63 \mu\text{in.}$, $3.2 \mu\text{m} = 125 \mu\text{in.}$

FIG. A7.1 Arc-Shaped Bend A(B) Specimen—Standard Proportions and Tolerances

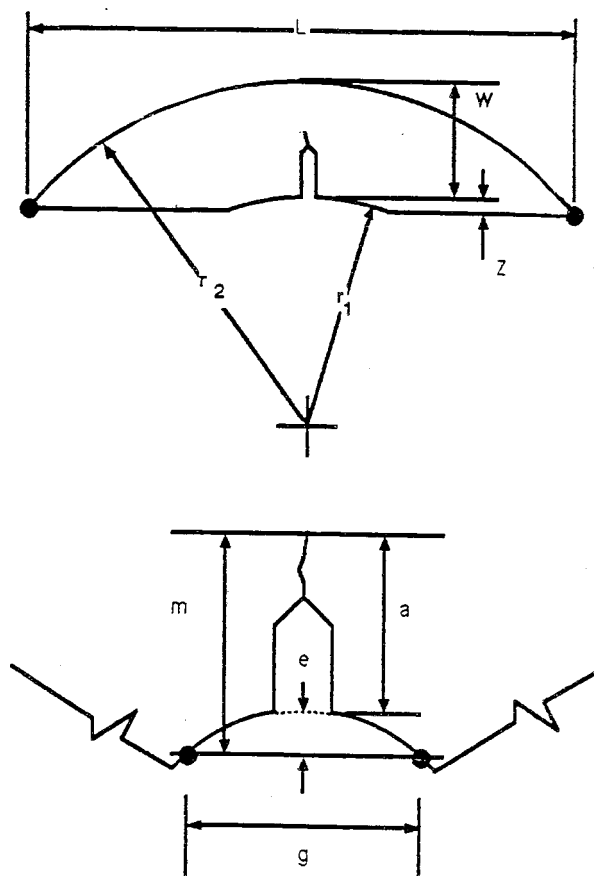

FIG. A7.2 Measurement of Outer Radius (r_2) and Crack Size for the Arc-Shaped Bend A(B) Specimen (see A7.4.1.1)

A7.3 Apparatus

A7.3.1 Bend Test Fixture—The loading fixture for standard bend specimen testing in Annex A3 is equally suitable for the arc-shaped bend specimen. The fixture is designed to minimize friction effects by allowing the rollers to rotate and translate slightly as the specimen is loaded, thus providing rolling contact.

A7.3.2 Displacement Gage—Details regarding displacement gage design, calibration, and use are given in 6.4. For the standard bend specimen, displacements are essentially independent of gage length up to $W/2$. It is presumed that for the cylindrical bend specimen, displacements are essentially independent of gage length up to $W/2$ as well.

A7.4 Procedure

A7.4.1 Measurement—Before testing, $(r_2 - r_1)$ is measured to the nearest 0.03 mm (0.001 in.) or to 0.1 %, whichever is greater, at mid-thickness positions on both sides of, and immediately adjacent to, the crack starter notch mouth. The average of these two readings is taken as W . Measurement of $(r_2 - r_1)$ is made also at four additional positions, two as close as possible to the intersection of the inside radius with the machined flat surfaces, and two at approximately one-half the circumferential distance between the machined flat surfaces and the crack plane. If any of these four measurements differ from W by more than 10 %, the specimen shall be discarded or

reworked. The distance in the crack plane between the chord that connects the two machined flat surfaces and the outer radius is measured to the nearest 0.03 mm (0.001 in.) or to 0.1 %, whichever is greater. This measurement is made on both sides of the specimen referencing each machined flat surface. Specimen width W is subtracted from the average of these two measurements and the difference recorded as the quantity Z . The distance g between the crack mouth opening displacement measurement reference points is measured to within 5.0 %. [It should be recognized that g may be equal to the crack slot width, N , (for example, $g = 6.4$ mm (0.25 in.) in Fig. 3) or larger than N if machined knife edges are used.] The outer radius r_2 is measured, if possible, to within 5.0 %. If not possible, then an average value of r_2 is calculated (see Note A6.1) from the measured (within 5.0 %) length, L , of the chord of the outer surface (that is, the chord established by the machined flat surfaces (see Fig. A7.2)) using the following relationship:

$$r_2 = \frac{L^2}{8(W+Z)} + \frac{W+Z}{2} \quad (A7.1)$$

then:

$$\frac{r_1}{r_2} = 1 - \frac{W}{r_2} \quad (A7.2)$$

NOTE A7.1—A 10 % variation in the ratio r_1/r_2 will affect the value of the stress-intensity factor by 1.2 % or less, providing that the relative crack length a/W is not less than 0.3. This, however, is based on the assumption that the specimen is cut from stock of uniform, axisymmetric cross section. If inspection shows that the stock deviates from axisymmetry by more than 10 %, it should be reworked to within this tolerance.

A7.4.1.1 Post-test crack size measurement (in accordance with 8.2.3) involves a special procedure due to the specimen's curvature. A size measurement, m , is made from a reference point on the curved inner surface, adjacent to the crack mouth, to a point on the crack front. That size is greater than the corresponding distance from the virtual point of intersection between the crack plane and the inside circumference of the specimen (see Fig. A7.2). Error, e , is computed from the following expression:

$$e = r_1 - \sqrt{r_1^2 - \frac{g^2}{4}} \quad (A7.3)$$

where g is the separation of the crack mouth opening displacement measurement reference points. If the relative error $e/m < 0.01$, then m is taken as the crack size; otherwise e is subtracted from m and the result recorded as the crack size.

A7.4.2 Arc-Shaped Bend Specimen Testing—General principles concerning the loading fixture and its setup appear in A2.1.

A7.4.2.1 The displacement gage is seated on the knife edges such as to maintain registry between knife edges and gage grooves. In the case of attachable knife edges, the gage is seated before the knife edge positioning screws are tightened.

A7.4.2.2 The specified rate of increase of the stress-intensity factor (see 8.3) ranges from 0.55 to 2.75 MPa $\sqrt{m/s}$ (30 to 150 ksi $\sqrt{in./min}$) and corresponds to a loading rate between 0.33 and 2.37 kN/s (4.5 to 32.0 klbf/min) for the standard ($W/B = 2$) 25 mm (1.0 in.) thick specimen with $S =$

3W, and between 0.24 and 1.71 kN/s (3.2 to 23.0 klbf/min) for the standard ($W/B = 2$) 25 mm (1.0 in.) thick specimen with $S = 4W$.

A7.4.2.3 Details concerning recording of the test record are given in 8.4.

A7.5 Calculations

A7.5.1 *Interpretation of Test Record*—General requirements and procedures for interpreting the test record are given in 9.1.

A7.5.2 *Validity Requirements*—Validity requirements in terms of limitation on P_{max}/P_Q and mandatory specimen size are given in 9.1.3 through 9.1.4.

A7.5.3 *Calculation of K_Q* —Arc-shaped bend specimen K_Q is calculated in SI or inch-pound units of $\text{Pa}\sqrt{\text{m}}$ ($\text{psi}\sqrt{\text{in.}}$) as follows (see Note A7.3):

For $S = 4W$:

$$K_Q = \frac{P_Q S}{B W^{3/2}} \left[1 + \left(1 - \frac{r_1}{r_2} \right) \cdot h_1 \left(\frac{a}{W} \right) \right] \cdot f_1 \left(\frac{a}{W} \right) \quad (\text{A7.4})$$

where:

$$h_1 \left(\frac{a}{W} \right) = 0.29 - 0.66 \frac{a}{W} + 0.37 \left(\frac{a}{W} \right)^2 \quad (\text{A7.5})$$

and:

$$f_1 \left(\frac{a}{W} \right) = \frac{\left[0.677 + 1.078 \frac{a}{W} - 1.43 \left(\frac{a}{W} \right)^2 + 0.669 \left(\frac{a}{W} \right)^3 \right]}{\left(1 - \frac{a}{W} \right)^{3/2}} \quad (\text{A7.6})$$

for $S = 3W$:

$$K_Q = \frac{P_Q S}{B W^{3/2}} \left[1 + \left(1 - \frac{r_1}{r_2} \right) \cdot h_2 \left(\frac{a}{W} \right) \right] \cdot f_2 \left(\frac{a}{W} \right) \quad (\text{A7.7})$$

where:

$$h_2 \left(\frac{a}{W} \right) = 0.20 - 0.32 \frac{a}{W} + 0.12 \left(\frac{a}{W} \right)^2 \quad (\text{A7.8})$$

and:

$$f_2 \left(\frac{a}{W} \right) = \frac{\left[0.644 + 1.11 \frac{a}{W} - 1.49 \left(\frac{a}{W} \right)^2 + 0.73 \left(\frac{a}{W} \right)^3 \right]}{\left(1 - \frac{a}{W} \right)^{3/2}} \quad (\text{A7.9})$$

for which:

- P_Q = force as determined in 9.1.1, N (lbf),
- B = specimen thickness as determined in 8.2.1, m (in.),
- S = span as determined in A7.4.2 and A2.1, m (in.),
- W = specimen width as determined in A7.4.1, m (in.),
- a = crack size as determined in 8.2.3 and A7.4.1.1, m (in.),
- r_1 = inner radius as determined in A7.4.1, m (in.), and
- r_2 = outer radius as determined in A7.4.1, m (in.).

NOTE A7.2—Example: for $a/W = 0.500$, $h_1(a/W) = 0.0525$, $f_1(a/W) = 2.66$, $h_2(a/W) = 0.0700$, and $f_2(a/W) = 2.60$.

NOTE A7.3—These expressions are considered to be accurate to within 1.0 % for $0.2 \leq a/W \leq 1.0$, $0.6 \leq r_1/r_2 \leq 1.0$, and $S = 4W$; and 1.5 % for $0.2 \leq a/W \leq 1.0$, $0.4 \leq r_1/r_2 \leq 1.0$, and $S = 3$ (25).

A8. FATIGUE PRECRACKING K_{Ic} FRACTURE TOUGHNESS SPECIMENS

A8.1 Introduction

A8.1.1 Experience has shown that even the narrowest practical machined notch cannot simulate a natural crack well enough to provide a satisfactory measurement of K_{Ic} . Recourse is made to an artifice consisting of a narrow notch from which extends a comparatively short fatigue crack, called the precrack. The dimensions of the notch and the precrack, and the sharpness of the precrack, must meet certain conditions which can be readily met with most engineering materials. There are, however, some materials that are too brittle to be fatigue cracked; they fracture at the onset of fatigue crack initiation. These are outside the scope of this test method. An exception is beryllium, which requires special fatigue precracking procedures that are described in Annex A9.

A8.1.2 The objective of fatigue precracking is to produce a sharp crack which is unaffected by the precracking procedure. In what follows, guidance is offered on the production of satisfactory fatigue precracks. Associated requirements to ensure a valid K_{Ic} test are also given.

A8.1.3 A fatigue precrack is produced by cyclically loading the notched specimen at a ratio of minimum-to-maximum stress between -1 and $+0.1$ for a number of cycles, usually between about 10^4 and 10^6 depending on specimen size, notch preparation, and cyclic stress-intensity factor level. The maximum stress-intensity factor, K_{max} , during any stage of fatigue crack growth shall not exceed 80 % of the K_Q value determined in the subsequent test if K_Q is to qualify as a valid K_{Ic} result. For the terminal stage of fatigue precracking (2.5 % of crack size a), K_{max} shall not exceed 60 % of K_Q . Some fraction of the total number of cycles required to produce the fatigue precrack is consumed in the initiation of the crack at the notch root; the remainder represents growth of the crack to the specified size. If the total number of cycles is excessive, the cause is usually an excessive number of cycles required for initiation rather than subsequent crack growth. Crack initiation can be hastened by: (1) increasing the acuity of the notch tip; (2) using a chevron starter notch (see Fig. 5) in place of a straight-through starter notch; (3) applying a static preload to the specimen such that the notch tip is compressed in a

direction normal to the intended crack plane, but without allowing the nominal compressive stress to exceed the compressive yield strength of the material; and (4) using a negative fatigue stress ratio.

A8.2 Equipment

A8.2.1 The fixtures recommended for fracture testing are also suitable for fatigue precracking at positive stress intensity ratios. K -calibration for the specimen using the fixtures shall be known with an error not exceeding 5.0 %. K -calibration is the relation between the stress-intensity factor K and either the force or some prescribed displacement and the specimen dimensions (1). If different fixtures are used, the appropriate K calibration shall be determined experimentally with those fixtures (7). The advantage of experimental K calibration, compared to numerical methods of analysis, is that accurate modeling of the boundary conditions with the actual fixtures is assured. It is important to bear in mind that if the fatigue cycle involves reversal of force, the K calibration can be very sensitive to the distribution of clamping forces necessary to grip the specimen.

A8.2.2 The fatigue cracking setup shall be such that the stress distribution is uniform through the specimen thickness; otherwise the crack will not grow uniformly. The stress distribution shall also be symmetrical about the plane of the prospective crack; otherwise the crack will deviate unduly from that plane and the test result will be significantly affected, possibly invalidated (7). A single obvious exception to these requirements is that of cantilever bending used only for fatigue precracking beryllium (see A3.2.3 and A9.2.3.2).

A8.3 Specimen Requirements

A8.3.1 Fatigue precracking shall be done with the specimen in the finally heat-treated, mechanically-worked, or environmentally-conditioned state in which it is to be tested.

A8.3.2 The combination of starter notch and fatigue precrack shall conform to the requirements of Fig. 5. The standard specified crack size ranges from $0.45W$ to $0.55W$ and is the total size of the starter notch slot plus fatigue crack. To facilitate fatigue precracking at a low level of stress intensity, the notch root radius of a straight-across notch should be no more than 0.08 mm (0.003 in.). The chevron notch (see Fig. 5) root radius can be as much as 0.25 mm (0.010 in.) because of the compound stress intensification at the point of the chevron. Crack initiation in either specimen variety can be accelerated by precompressing the notch tip region, as stated in A8.1.3.

A8.3.3 It is suggested that two pencil lines be marked on each side of the specimen normal to the anticipated crack-path surface traces. The line most distant from the notch tip shall indicate the minimum required size of fatigue crack; the other (at a lesser distance) the terminal part of that size equal to not less than 2.5 % of the overall crack size of notch plus fatigue crack; that is, $0.0125 W$. During the final stage of fatigue crack extension, for at least this distance, the ratio of maximum stress-intensity factor of the fatigue cycle to the Young's modulus of the material, K_{max}/E , shall not exceed $0.0003 \sqrt{m}$

($0.002 \sqrt{\text{in.}}$). Furthermore, K_{max} must not exceed 60 % of the K_Q value determined in the subsequent test if K_Q is to qualify as a valid K_{Ic} result.

A8.4 Precracking Procedure

A8.4.1 Fatigue precracking normally shall be done at room temperature with the specimen in the finally heat-treated, mechanically-worked, or environmentally-conditioned state in which it is to be tested. Different fatigue precracking temperatures and intermediate thermal/mechanical/environmental treatments between fatigue precracking and testing shall be used only when such treatments are necessary to simulate the conditions for a specific structural application and required dimensions and tolerances on specimen size and shape can be maintained.

A8.4.2 Fatigue precracking may be conducted under either force control or displacement control provided that the appropriate K -calibration is known with requisite accuracy for the specimen and fixture (see A8.2.1). If the force range is maintained constant, K_{max} and the K range (ΔK) will increase with crack size; if the displacement range is maintained constant, the opposite will happen. The initial value of the maximum fatigue force or displacement shall be calculated from the K calibration and the specimen and notch dimensions. It is suggested that this force be selected such that the maximum stress-intensity factor in the initial portion of the fatigue cycle does not exceed 80 % of the estimated K_{Ic} value of the material. Higher K_{max} values may result in undesirably high crack growth rates. The minimum is then selected so that the stress ratio is between -1 and $+0.1$. The more negative the stress ratio, the faster the fatigue precrack will be completed, but this advantage is offset by the need for more elaborate fixtures than are required when the stress ratio is positive.

A8.4.3 The specimen shall be accurately located in the loading fixture and secured as required so that the boundary conditions correspond to the applicable K calibration. Fatigue cycling is then begun, usually with a sinusoidal waveform and near to the highest practical frequency. There is no known marked frequency effect on fatigue precrack formation up to at least 100 Hz in the absence of adverse environments. The specimen shall be carefully monitored until crack initiation is observed on one side. If crack initiation is not observed on the other side before appreciable growth is observed on the first, then fatigue cycling should be stopped to try to determine the cause and remedy for the unsymmetrical behavior. Sometimes, simply turning the specimen end for end in relation to the fixture will solve the problem. When the most advanced crack trace has almost reached the first scribed line corresponding to 97.5 % of the final crack size, the maximum force or displacement, as appropriate, shall be reduced so that the terminal value of K_{max} is unlikely to exceed 60 % of the estimated minimum value of K_{Ic} of the material, and also that the terminal value of K_{max}/E will not exceed $0.0003 \sqrt{m}$ ($0.002 \sqrt{\text{in.}}$). The minimum setting is then adjusted so that the stress ratio is between -1 and $+0.1$. Fatigue cycling is then continued until the surface traces on both sides of the specimen indicate

that the overall size of notch plus crack will meet the requirements of 7.3.2.1 and 7.3.2.2, and Fig. 5 of this test method.

A8.4.4 When fatigue cracking is conducted at temperature T_1 and testing at different temperature T_2 , $K_{max(T_1)}$ shall not

exceed $0.6[(\sigma_{ys(T_1)}/\sigma_{ys(T_2)}) [K_{Q(T_2)} = K_{Ic(T_2)}]]$, where $\sigma_{ys(T_1)}$ and $\sigma_{ys(T_2)}$ are the yield strengths at the respective temperatures T_1 and T_2 .

A9. SPECIAL REQUIREMENTS FOR TESTING HOT-PRESSED BERYLLIUM

A9.1 Scope

A9.1.1 This Annex describes special requirements for determining the plane-strain fracture toughness of hot pressed beryllium. With only few exceptions, the provisions of Test Method E399 are applicable to the fracture toughness testing of beryllium. However, certain modifications to specimen preparation and record analysis, as described in this Annex, arise because of beryllium's potential toxicity, inherent brittleness associated with cleavage fracture, high elastic modulus, nonlinear-elastic behavior, and very high fatigue crack growth rates (26, 27).

NOTE A9.1—Inhalation of dust or fumes from metallic beryllium, beryllium oxide, or soluble beryllium compounds can result in systemic disease. Machining and testing of beryllium require special precautions and an industrial hygienist familiar with OSHA Standards should be consulted before a beryllium test program is started.

A9.2 Specimen Size, Configuration and Preparation

A9.2.1 *Specimen Size*—The thickness of hot-pressed beryllium specimens shall be 13 mm (0.50 in.) or greater to avoid excessive nonlinearity in the elastic portion of the force-CMOD record.

A9.2.2 *Specimen Configuration*—Standard bend SE(B) or compact C(T) specimens may be used. A straight-through notch (see Fig. 5) shall be used to provide sufficient fatigue crack extension in the required reversed loading.

A9.2.3 Specimen Preparation:

A9.2.3.1 *Machining*—Beryllium is easy to machine. Nonetheless, machining damage is frequently encountered and tensile test specimens are therefore etched to remove the damaged layer. Experience has shown, however, that such is not required in the preparation of beryllium fracture toughness specimens (28).

A9.2.3.2 *Fatigue Cracking*—Fatigue cracking is done in reverse loading, with the compression cycle 2 to 3 times that of the tension cycle ($-3 < R < -2$). Under such loading, the fatigue crack growth rate decreases with crack extension, and it is necessary to gradually increase the tension cycle level to develop sufficiently long cracks. Generally, for the final 2.5 % of crack growth, tension force exceeding 60 % of the anticipated K_{Ic} value will be required. To prevent the specimen from breaking, values of K_{max} greater than 80 % of the anticipated K_{Ic} shall be avoided. As a guideline, K_{Ic} at room temperature and in normal laboratory environments may be assumed to be between 10 and 11 MPa√m (9 and 10 ksi√in.). Fatigue crack progress is to be observed on both sides of the specimen. It has

proven helpful to use a dye solution (such as those used for penetrant inspection) to delineate the crack since crack opening is relatively small due to the high elastic modulus of this metal. Fatigue cracking of compact specimens in tension-compression loading is especially difficult. A special gripping arrangement is described in (29). Fatigue cracking SE(B) specimens has been successfully accomplished in cantilever bending (26, 30). The expression in A3.5.3 for K_Q applicable to three-point bending is used as a conservative approximation of K_{max} for cantilever bending (substituting, of course, maximum fatigue force for P_Q). An approximation (31) obtained by curve-fitting the compliance calibration data of (7) for a cantilever bend specimen with $L/W = 2$, is (see Note A9.3) (in units of Pa√m (psi√in.):

$$K_{max} = \frac{PL}{BW^{3/2}} f\left(\frac{a}{W}\right) \quad (A9.1)$$

where:

$$f\left(\frac{a}{W}\right) = 0.326 + 30.318\frac{a}{W} - 59.905\left(\frac{a}{W}\right)^2 + 68.889\left(\frac{a}{W}\right)^3 \quad (A9.2)$$

for which:

- P = maximum cyclic force, N (lbf),
- L = $S/2$ = one-half span, m (in.), and
- $S, B, W,$ and a are as defined in A3.5.3 or A4.5.3.

NOTE A9.2—Example: for $a/W = 0.500$, $f(a/W) = 9.12$.

NOTE A9.3—This expression is considered to be accurate within 5.0 % for $a/W \leq 0.6$ (7).

A9.2.3.3 When using cantilever bending, excessive clamping forces will produce cracks at the specimen edges that will invalidate the test.

A9.3 Testing and Record Analyses

A9.3.1 Forces and displacements will be relatively low, and the production of a satisfactory test record will require high gain in the clip gage circuit. It is advantageous to use a relatively slow loading rate corresponding to about 0.18 MPa√m/s (10 ksi√in./min) in order to provide sufficient time to unload the specimen if the recording gain controls require adjustment to achieve the slope range specified by this test method. When the elastic portion of the force-versus-CMOD record is nonlinear, an initial slope is determined by drawing a straight line between two points on the force-CMOD record; one point at 20 % of maximum force, the other at 80 % of maximum force.

A9.4 Precision and Bias (see also Section 11)

A9.4.1 Hot pressed beryllium from two suppliers was tested in six laboratories in accordance with the procedures of this Annex with the following results:

	Batch 1	Batch 2
σ_{ys}	236 MPa (34.3 ksi)	197 MPa (28.6 ksi)
Grand Mean, \bar{X}	10.7 (9.72)	10.4 (9.50)
Standard Deviation, S	0.93 (0.85)	0.78 (0.71)

NOTE A9.4—Units of grand mean and standard deviation are MPa \sqrt{m} (ksi $\sqrt{in.}$).

A9.4.2 The tensile elongation of beryllium depends on temperature and strain rate, but the magnitude of such variability on K_{Ic} is not known. However, the results of an interlaboratory program (28) did not appear influenced by loading rates which varied from 0.20 to 2.62 MPa $\sqrt{m/s}$ (11 to 143 ksi $\sqrt{in./min}$).

A10. SPECIAL REQUIREMENTS FOR RAPID-FORCE, PLANE-STRAIN FRACTURE TOUGHNESS $K_{Ic}(t)$ TESTING

A10.1 Scope

A10.1.1 This Annex specifies the method for determining plane-strain fracture toughness (K_{Ic}) of metallic materials at loading rates exceeding those for conventional (quasi-static) testing [that is, rates exceeding 2.75 MPa $\sqrt{m/s}$ (150 ksi $\sqrt{in./min}$)].

A10.2 Summary of Requirements

A10.2.1 The special requirements described in this Annex for plane-strain fracture toughness testing at loading rates exceeding those for conventional (quasi-static) plane-strain fracture toughness tests do not apply to impact or quasi-impact testing (free-falling or swinging masses). They apply only to rapid loading of conventional fracture toughness specimens to the measurement point in not less than one millisecond. Force versus time, crack mouth opening displacement (CMOD) versus time, and force versus CMOD curves are recorded. The initial linear portion of the force versus CMOD record must define P_Q unambiguously. The test time and an optionally calculated average stress-intensity factor rate \dot{K} characterize the rapid-force load test. The yield strength used in analysis of the test data can be measured directly or estimated for the loading time of the fracture test. All criteria for quasi-static K_{Ic} determination apply equally to the rapid-force test. The rapid-force, plane-strain fracture toughness property is denoted by $K_{Ic}(\)$, where the time to reach the force corresponding to K_Q is indicated in milliseconds within the brackets ().

A10.3 Significance and Use

A10.3.1 The significance of conventional (quasi-static) K_{Ic} applies also to rapid-force $K_{Ic}(t)$. The plane-strain fracture toughness of certain materials may be sensitive to the loading rate and decreased toughness may be noted as the loading rate increases.

A10.4 Terminology

A10.4.1 Definitions:

A10.4.1.1 The definitions given in Terminology E1823 and Section 3 apply to this Annex.

A10.4.1.2 *stress-intensity factor rate*, \dot{K} (FL^{-3/2} t⁻¹)—change in stress-intensity factor, K , per unit time.

A10.4.2 Description of Terms Specific to This Annex:

A10.4.2.1 *rapid force*—any force in fracture testing that results in an average stress-intensity factor rate in excess of 2.75 MPa $\sqrt{m/s}$ (150 ksi $\sqrt{in./min}$).

A10.4.2.2 *rapid-force plane-strain fracture toughness*, $K_{Ic}(t)$ (FL^{-3/2})—the crack extension resistance under conditions of crack-tip plane strain at average loading rates exceeding 2.75 MPa $\sqrt{m/s}$ (150 ksi $\sqrt{in./min}$). The time, t , in milliseconds to reach P_Q is indicated in the brackets () following K_{Ic} .

A10.5 Apparatus

A10.5.1 *Loading*—Hydraulic machines with rapid-acting servo-controlled valves are generally used. Depending on the compliance of the loading system and the pump capacity, an accumulator may be required.

A10.5.2 *Fixtures*—Fixtures used for quasi-static, plane-strain fracture toughness tests are generally suitable for rapid-force tests, except rapid-force fixtures are to be fabricated from materials unaffected by rapid loading.

A10.5.3 *Force and Displacement Transducers*—The transducers used for quasi-static, plane-strain fracture toughness tests are generally suitable for rapid-force tests. However, these transducers must have response characteristics without inertial effects that could contaminate the force and displacement signals.

NOTE A10.1—While not required, the resonant frequencies of these transducers may be determined by suitably exciting them and observing the wave characteristic on an oscilloscope. If ringing (high frequency oscillation) is observed within the time period required to reach force P_Q , the stiffness of the transducers is to be increased or the mass reduced. Force transducers are usually stiff and are unlikely to be problematical at the loading time minimum of 1 ms. On the other hand, the displacement transducer might be cause for concern depending on its design. The cantilever beam displacement gage described in Annex A1 has been used successfully at loading times slightly lower than 1 ms (32). The resonant frequency of the gage when mounted on a specimen in a conventional manner and excited by tapping is about 3300 Hz. The free-arm resonant frequency is about 750 Hz. Other gages of the same type, but having different dimensions, should operate satisfactorily if their free arm resonance is at least 750 Hz. The following equation may be used to estimate the free-arm resonant frequency of such gages:

$$f = C(0.162) \sqrt{\frac{b^2 Eg}{\rho l^4}} \quad (\text{A10.1})$$

where:

f = resonant frequency, Hz,

- C = dimensional constant, 0.319 for SI and 1.0 for inch-pound,
- b = arm thickness, m (in.),
- E = elastic modulus of the arms, Pa (psi),
- g = gravitational acceleration, 9.807 m/s² (386 in./s²),
- ρ = density of the arm material in, kg/m³ (lbm/in.³), and
- l = length of the uniform-thickness section of the arm, m (in.).

A10.5.4 *Signal Conditioners*—Amplification or filtering of the transducer signals may be necessary. Such signal conditioning devices are to have frequency response from dc to at least $20t^{-1}$ (kHz) where t is the test time in ms as defined in A10.7.2. Conventional mechanical recording devices may not have sufficient frequency response to permit direct plotting of the force versus time and the displacement versus time signals.

A10.6 Procedure

A10.6.1 *Loading Rate*—The rate of loading is discretionary, but the time to reach the force corresponding to K_Q shall be not less than 1 ms. A preload is permitted to eliminate ringing in the force or displacement transducers associated with the closing of clearances in the load train at the start of rapid loading.

A10.6.2 For every test, force versus time, crack mouth opening displacement (CMOD) versus time, and force versus CMOD records shall be obtained. The time scale of the records shall be accurately determined, as the time is used to characterize the test. The time-dependent records are to be examined for the presence of ringing before reaching the P_Q force. Ringing can result from the inertial effects described in Note A10.1. The special record analysis procedure described in A10.7.2 may be helpful in assessing the magnitude of such effects.

NOTE A10.2—It should be recognized that some materials may exhibit a burst of crack extension at forces less than P_Q , sufficiently abrupt to produce ringing in the displacement transducer signal. Such an abrupt advance of the crack may be associated with material inhomogeneities local to the fatigue crack tip. If the ringing is severe, it may not be possible to unambiguously determine P_Q . The presence of such bursts of crack extension should be recorded for those tests having analyzable force versus CMOD records.

NOTE A10.3—Test data may be directly recorded if the recording device has sufficient frequency response. Generally, it is advantageous to use a storage device that will capture the data and permit playing it out at a sufficiently slow speed that a pen recorder can be used to produce the required record. Such storage devices are commonly available in the form of digital storage oscilloscopes having pen recorder outputs. Separate storage instruments are also available. In general, these digital storage devices have performance characteristics that are more than adequate to capture, store, and replay the transducer signals from a 1 ms test. Calculations show, for example, that for a typical fracture test as described in (32), the crack mouth opening displacement (CMOD) resolution would be approximately 0.76 $\mu\text{m/sample}$ (0.030 mils/sample) and the force resolution would be approximately 712 N/sample (160 lbf/sample). It should be possible to obtain at least 1000 simultaneous samples of force and CMOD during such a test. A digital storage scope capable of at least this performance would have the following characteristics: maximum digitizing rate 1 MHz, maximum sensitivity ± 100 mV, resolution 0.025 %, and memory of 4096 words by 12 bits. It may be necessary to amplify the output of the clip gage moderately, and possibly that of the force transducer depending on its capacity in terms of the range required. The above values of resolution are based on a total noise figure of approximately 50 μV .

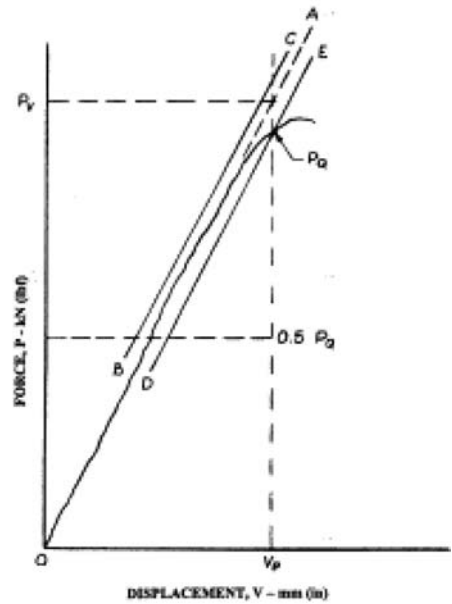

FIG. A10.1 Special Requirements for Analysis of Force-Displacement Records (5 % Secant Line Not Shown)

A10.7 Calculation and Interpretation of Results

A10.7.1 Special requirements are placed on the analysis of the rapid-force versus CMOD record, because experience (32) has shown these records to be frequently not as smooth in the linear range as those obtained from quasi-static tests. The special requirements of this annex are designed to ensure that an unambiguous value of P_Q can be determined.

A10.7.1.1 The rapid-force versus CMOD record is illustrated in Fig. A10.1. It is analyzed as follows: Straight line OA is constructed to best represent the initial portion of the test record, which ideally should be linear but may not be smooth. Line OP_5 is then constructed as described in 9.1.1 (see Fig. 7) to determine P_Q . A vertical line is drawn at v_p passing through P_Q . P_v is defined at the point of intersection of this line with the line OA . Lines BC and DE are drawn parallel to OA , with BC passing through $(P_v + 0.05P_v)$, and DE passing through $P_Q (P_v - 0.05P_v)$. A horizontal line is drawn at $P = 0.5P_Q$. For the test to be valid, the rapid-force versus CMOD curve up to P_Q must lie within the envelope described by these parallel lines for that portion of the record with $P \geq 0.5P_Q$.

A10.7.2 Test time t in milliseconds is determined from the record of force versus time shown schematically in Fig. A10.2. The best straight line OA is drawn through the most nearly linear portion of the record. Time t is represented as the span from the intersection of this line with the time axis, to the intersection with the time axis of a vertical line from P_Q . This time t is reported in the brackets () following the K_{Ic} value. An average stress intensity rate \dot{K} is calculated by dividing K_Q or K_{Ic} by t , the result being expressed in $\text{MPa}\sqrt{\text{m/s}}$ or $\text{ksi}\sqrt{\text{in./s}}$. Minor errors in determining the loading time are not important because significant changes in toughness require several orders of magnitude change in loading rate.

A10.7.3 The 0.2 % offset tensile yield strength σ_{ys} is used in determining satisfaction of the specimen size requirements

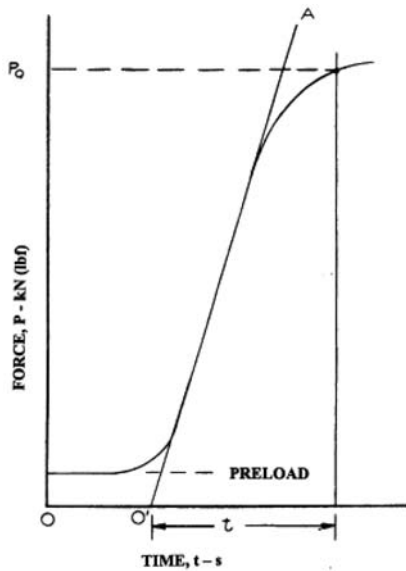

FIG. A10.2 Determination of Test Time from Force-Time Record

t = loading time in ms (see A10.7.2), and
 T_x = temperature of rapid-force toughness test.

Units:

For σ_{YS} in MPa, $A = 1\,198\,860$ and $B = 187$ MPa
 For σ_{YS} in ksi, $A = 174\,000$ and $B = 27.2$ ksi
 For T in °F, $T_x = (T + 460)$
 For T in °K, $T_x = 1.8(T)$

NOTE A10.4—The equation in A10.7.3.2 has been found useful only in estimating the low temperature dynamic yield strength of constructional steels having room temperature yield strengths below 483 MPa (70 ksi).

A10.8 Report

A10.8.1 The test report shall include the following additional information:

A10.8.1.1 Test time (in milliseconds) written in () after K_Q or K_{Ic} .

A10.8.1.2 Method by which σ_{YD} of A10.7.3 was determined.

A10.8.1.3 Indications of ringing, before P_Q is reached, in the force versus time or displacement versus time record.

A10.9 Precision and Bias

A10.9.1 *Precision*—Eighteen valid values of $K_{Ic}(t)$ at -51°C (-60°F) have been reported (32), with σ_{YD} determined by extrapolation of dynamic tensile yield strength values obtained at strain rates from 0.01 s^{-1} to 1.0 s^{-1} at temperatures from room to -40°C (-40°F). No statistical analysis of the dynamic tensile yield strength data was made. The rapid-force, plane-strain fracture toughness tests represented standard bend SE(B) and compact C(T) specimens tested in three thicknesses by seven laboratories. Not all laboratories tested all thicknesses. Statistical tests for outliers and for the differences between means indicated that the data should be pooled. Considering all the valid data, the grand mean $X = 61.14\text{ MPa}\sqrt{\text{m}}$ ($55.64\text{ ksi}\sqrt{\text{in.}}$); the standard deviation $S = 8.68\text{ MPa}\sqrt{\text{m}}$ ($7.90\text{ ksi}\sqrt{\text{in.}}$) and the coefficient of variation = 14 % of the average.

A10.9.2 *Bias*—There is no accepted “standard” value for the plane-strain fracture toughness of any material. In the absence of such a true value, any statement concerning bias is meaningless.

described in 9.1.4 for test validity. If the rapid-force K_Q is valid as K_{Ic} using a quasi-static yield strength value determined at a temperature at or above that of the rapid-force test, no further yield strength considerations is necessary.

A10.7.3.1 If the test is invalid using the quasi-static yield strength, it will be necessary to conduct a supplementary tension test on the test material at the temperature and loading time of the rapid-force toughness test, with the time to reach the yield force in the tension test approximately equal to the time t defined in A10.7.2.

A10.7.3.2 In the absence of rapid-force load σ_{ys} values as defined in A10.7.3.1, the dynamic yield strength σ_{YD} of certain steels may be estimated using the following equation (33, 34):

$$\sigma_{YD} = \sigma_{ys} + \frac{A}{T_x \cdot \text{Log}(2 \cdot 10^7 t)} - B \quad (\text{A10.2})$$

where:

σ_{ys} = 0.2 % offset room temperature quasi-static yield strength,

REFERENCES

- (1) Brown, W. F., Jr., and Srawley, J. E., “Plane Strain Crack Toughness Testing of High Strength Metallic Materials,” *ASTM STP 410*, 1966.
- (2) Srawley, J. E., “Plane Strain Fracture Toughness,” *Fracture*, Vol 4, Ch. 2, p. 45–68.
- (3) Wessel, E. T., “State of the Art of the WOL Specimen for K_{Ic} Fracture Toughness Testing,” *Engineering Fracture Mechanics*, Vol 1, No. 1, January 1968.
- (4) Srawley, J. E., Jones, M. H., and Brown, W. F., Jr., “Determination of Plane Strain Fracture Toughness,” *Materials Research and Standards*, ASTM, Vol 7, No. 6, June 1967, p. 262.
- (5) Jones, M. H., and Brown, W. F., Jr. “The Influence of Crack Length and Thickness in Plane Strain Fracture Toughness Tests,” *ASTM STP 463*, 1970, p. 63.
- (6) Bray, G. H., “Literature Review on Use of Side Grooves in Linear-Elastic Fracture Toughness Testing: Supporting Document for E08.07 Ballot Item 6 (April 2006) Detailed references added Jan. 2007”.
- Contact Dr. Mark James. Mark.A.James@alcoa.com
- (7) Fisher, D. M., and Repko, A. J., “Note on Inclination of Fatigue Cracks in Plane Strain Fracture Toughness Test Specimens,” *Materials Research and Standards*, ASTM, Vol 9, No. 4, April 1969.
- (8) Heyer, R. H., and McCabe, D. E., “Evaluation of a Test Method for Plane-Strain Fracture Toughness Using a Bend Specimen,” *ASTM STP 463*, 1970, p. 22.
- (9) McCabe, D. E., “Evaluation of the Compact Tension Specimen for Determining Plane-Strain Fracture Toughness of High Strength Materials,” *Journal of Materials*, Vol 7, No. 4, December 1972, p. 449.
- (10) Underwood, J. H., and Kendall, D. P., “Cooperative Plane Strain Fracture Toughness Tests with C-Shaped Specimens,” *Journal of Testing and Evaluation*, Vol 6, No. 5, September 1978, p. 296.
- (11) McCabe, D. E., “Evaluation of the Compact Tension Specimen for Plane Strain Fracture Toughness of High Strength Materials,”

- Journal of Materials*, Vol 7, No. 4, December 1972, p. 449.
- (12) Orange, T. W., "Some Effects of Experimental Error in Fracture Testing," *Fracture Analysis*, ASTM STP 560, 1974, pp. 122–133.
 - (13) Fisher, D. M., Bubsey, R. T., and Srawley, J. E., "Design and Use of a Displacement Gage for Crack Extension Measurements," *NASA TN-D-3724*, Nat. Aeronautics and Space Administration, 1966.
 - (14) Baratta, F. I. and Fett, T., "The Effect of Load and Crack Misalignment on Stress Intensity Factors for Bend Type Fracture Toughness Specimens," *Journal of Testing and Evaluation*, Vol 28, No. 2, March 2000, pp. 96–102.
 - (15) Jones, M. H., Bubsey, R. T., and Brown, W. F., Jr., "Clevis Design for Compact Tension Specimens Used in K_{Ic} Testing," *Materials Research and Standards*, ASTM, Vol 9, No. 5, May 1969.
 - (16) Freese, C. E. and Baratta, F. I., "Single Edge-Crack Stress Intensity Factor Solutions," *Engineering Fracture Mechanics*, Vol 73, 2006, pp. 616–625.
 - (17) Tada, H., Paris, P. C., and Irwin, G. R., "*The Stress Analysis of Cracks Handbook*," Del Research Corporation, Hellertown, PA, 1973.
 - (18) Wu, S. X., "Crack Length Calculation Formula for Three-Point Bend Specimens," *International Journal of Fracture*, Vol 24, 1984, pp. R33–R35.
 - (19) Srawley, J. E., "Wide Range Stress Intensity Factor Expressions for ASTM E399 Standard Fracture Toughness Specimens," *International Journal of Fracture*, Vol 12, June 1976, p. 475.
 - (20) Newman, J. C., "Stress Analysis of Compact Specimens Including the Effects of Pin Loading," *ASTM STP 560*, 1974, p. 105.
 - (21) Kapp, J. A., "Improved Wide Range Expressions for Displacements and Inverse Displacements for Standard Fracture Mechanics Specimens," *Journal of Testing and Evaluation*, JTEVA, Vol 19, No. 1, January 1991, pp. 45–54.
 - (22) Underwood, J. H., Newman, J. C., Jr., and Seeley, R. R., "A Proposed Standard Round Compact Specimen for Plane Strain Fracture Toughness Testing," *Journal of Testing and Evaluation*, Vol 8, No. 6, November 1980, p. 308–313.
 - (23) Newman, J. C., Jr., "Stress Intensity Factors and Crack Opening Displacements for Round Compact Specimens," *International Journal of Fracture*, Vol 17, No. 6, December 1981, pp. 567–578.
 - (24) Kapp, J. A., Newman, J. C., Jr., and Underwood, J. H., "A Wide Range Stress Intensity Factor Expression for the C-Shaped Specimen," *Journal of Testing and Evaluation*, Vol 8, No. 6, November 1980, pp. 314–317.
 - (25) Underwood, J. H., "Proposed Standard Arc-Bend Chord-Support Fracture Toughness Specimens and K Expressions," *Journal of Testing and Evaluation*, JTEVA, Vol 17, No. 4, July 1989, pp. 230–233.
 - (26) Jones, M. H., Bubsey, R. T., and Brown, W. F. Jr., "Crack Toughness Evaluation of Hot Pressed and Forged Beryllium," *Journal of Testing and Evaluation*, JTEVA, Vol 1, No. 2, March 1973, pp. 100–109.
 - (27) Lemon, D. D., and Brown, W. F., Jr., "Fracture Toughness of Hot Pressed Be," *Journal of Testing and Evaluation*, JTEVA, Vol 13, No. 2, March 1985, p. 152.
 - (28) Conrad, H., and Sargent, G. A., "To Establish a Standard ASTM Method for Fracture Toughness Testing of Beryllium," NASA Grant NSG3013, Oct. 1977, ASTM Research Report No. RR:E24-1005.
 - (29) Shabbits, W. O., and Logsdon, W. A., "S-200 Grade Beryllium Fracture Toughness Properties," *Journal of Testing and Evaluation*, JTEVA, Vol 1, No. 2, March 1973, pp. 110–118.
 - (30) Conrad, H., Sargent, G. A., and Brown, W. F., Jr., "A Joint Fracture Toughness Evaluation of Hot Pressed Beryllium," *Beryllium Conference*, The Royal Society, London, 1977, Paper 21.
 - (31) Baratta, F. I., Private Communication, 21 Nov 1989. ASTM Research Report RR:E24-1015.
 - (32) Shoemaker, A. K., and Seeley, R. R., "Summary Report of Round-Robin Testing by the ASTM Task Group E24.01.06 on Rapid Loading Plane-Strain Fracture Toughness K_{Ic} Testing," *Journal of Testing and Evaluation*, JTEVA Vol 11, No. 4, July 1983 pp. 261–272.
 - (33) Madison, R. B., and Irwin, G. R., "Dynamic K_c Testing of Structural Steel," *Journal of the Structural Division*, ASCE, Vol 100, No. ST 7, Proceedings paper 10653, July 1974, p. 1331.
 - (34) Irwin, G. R., Krafft, J. M., Paris, P., and Wells, A. A., "Basic Aspects of Crack Growth and Fracture," *NRL Report 6598*, Naval Research Laboratory, November 1967.
 - (35) Merkle, J. G., Wallin, K., and McCabe, D. E., "Technical Basis for an ASTM Standard on Determining the Reference Temperature T_0 for Ferritic Steels in the Transition Range," NUREG/CR-5504 (ORNL/TM-13631), November 1998.
 - (36) Petti, J. and Dodds, R. H., "Input on Side-Grooved Specimen Discussion for E399" Department of Civil and Environmental Engineering University of Illinois at Urbana-Champaign, Oct. 24, 2003. Contact Dr. Mark James. Mark.A.James@alcoa.com

ASTM International takes no position respecting the validity of any patent rights asserted in connection with any item mentioned in this standard. Users of this standard are expressly advised that determination of the validity of any such patent rights, and the risk of infringement of such rights, are entirely their own responsibility.

This standard is subject to revision at any time by the responsible technical committee and must be reviewed every five years and if not revised, either reapproved or withdrawn. Your comments are invited either for revision of this standard or for additional standards and should be addressed to ASTM International Headquarters. Your comments will receive careful consideration at a meeting of the responsible technical committee, which you may attend. If you feel that your comments have not received a fair hearing you should make your views known to the ASTM Committee on Standards, at the address shown below.

This standard is copyrighted by ASTM International, 100 Barr Harbor Drive, PO Box C700, West Conshohocken, PA 19428-2959, United States. Individual reprints (single or multiple copies) of this standard may be obtained by contacting ASTM at the above address or at 610-832-9585 (phone), 610-832-9555 (fax), or service@astm.org (e-mail); or through the ASTM website (www.astm.org). Permission rights to photocopy the standard may also be secured from the ASTM website (www.astm.org/COPYRIGHT/).